

BALT[®]

JPM-1 **Just Pure Magic** **Adjustable Printer Stand**

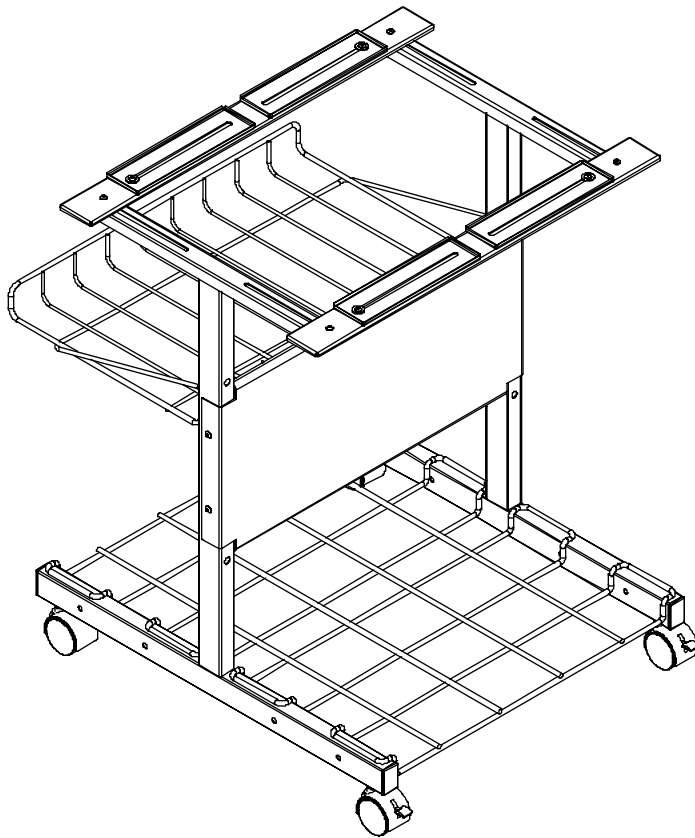

Assembly Instructions

Just Pure Magic Printer Stand JPM-1

Part	Drawing	Description	Qty	Part	Drawing	Description	Qty
P-1		Leg Frame	2 EA	Hardware List			
P-2		Back Stability Panel	1 EA	A		Flat Head Screw	12 EA
P-3		Long Metal Plates	2 EA	A1		Square Shoulder Screw	4 EA
P-4		Short Metal Plates	4 EA	B		Interior Threaded Post	4 EA
P-5		Forms Basket	1 EA	C		Leveling Feet	4 EA
P-6		Forms Rack	1 EA	D		2" Locking Casters (for Front)	2 EA
				E		2" Casters (for Back)	2 EA
				F		Allen Wrench	1 EA
				G		Caster Wrench	1 EA
				H		Cable Clips	4 EA
				J		Wing Nuts	8 EA
				K		Flat Washer	8 EA

To Assemble:

1. Identify and Separate all the Parts and Hardware.

2. Attach Back Stability Panel (P-2) to 2 Leg Frames (P-1) using 4 Flat head Screws (A) and 4 Interior Threaded Posts (B) as shown in illustration # 1.
(Do not tighten the screws all the way)

3. Attach 4 Leveling feet (C) or Casters to the Leg Frames [If casters, 2 Locking casters (D) in the front and 2 Casters (E) in the back. Tighten the Casters using Caster Wrench (G)]

Illustration # 1

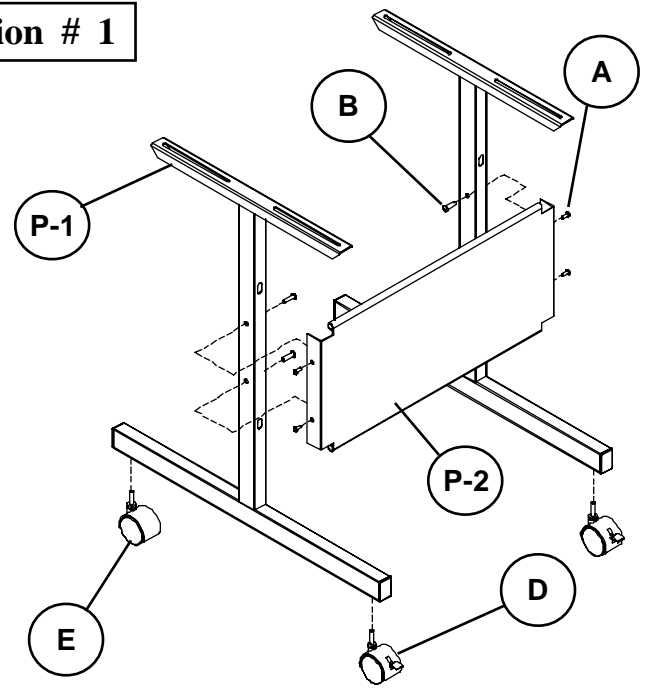

Do not use unless all screws are tight. At least every six months, check all screws to be sure they are tight. If parts are missing, broken, damaged, or worn, stop use of the product until repairs are made by your dealer using factory authorized parts.



JPM-1 Just Pure Magic Adjustable Printer Stand Assembly Diagram

4. Attach 2 Long Metal Plates (P-3) and 4 Short Metal plates (P-4) to the Leg Assembly (P-1) using 4 Square Shoulder Screws (A1), Flat Washers (K) and Wing Nuts (J).

See back page for different options. [Option #3 shown here.]

Note: Long Metal Plates should be attached with Channel side down, and Short Metal Plates with the channel side up.

Illustration # 2

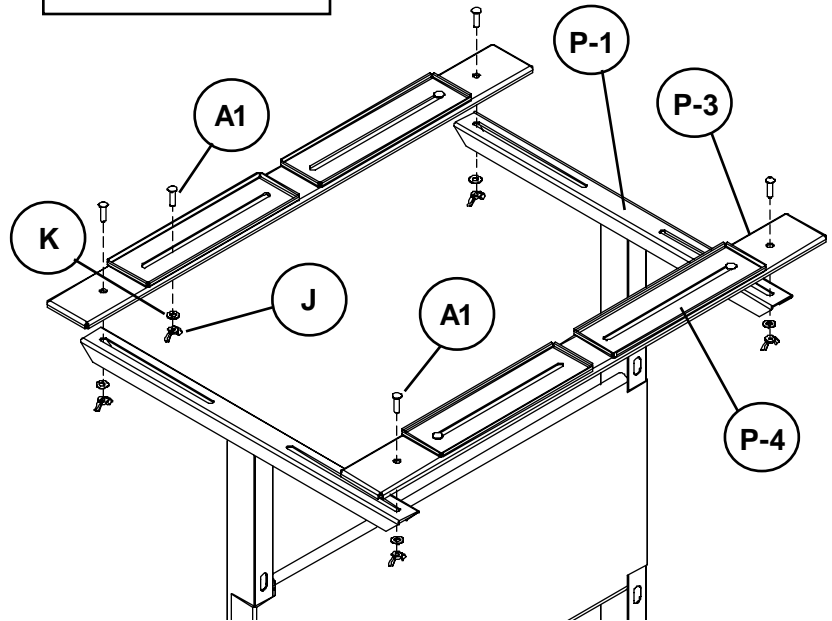
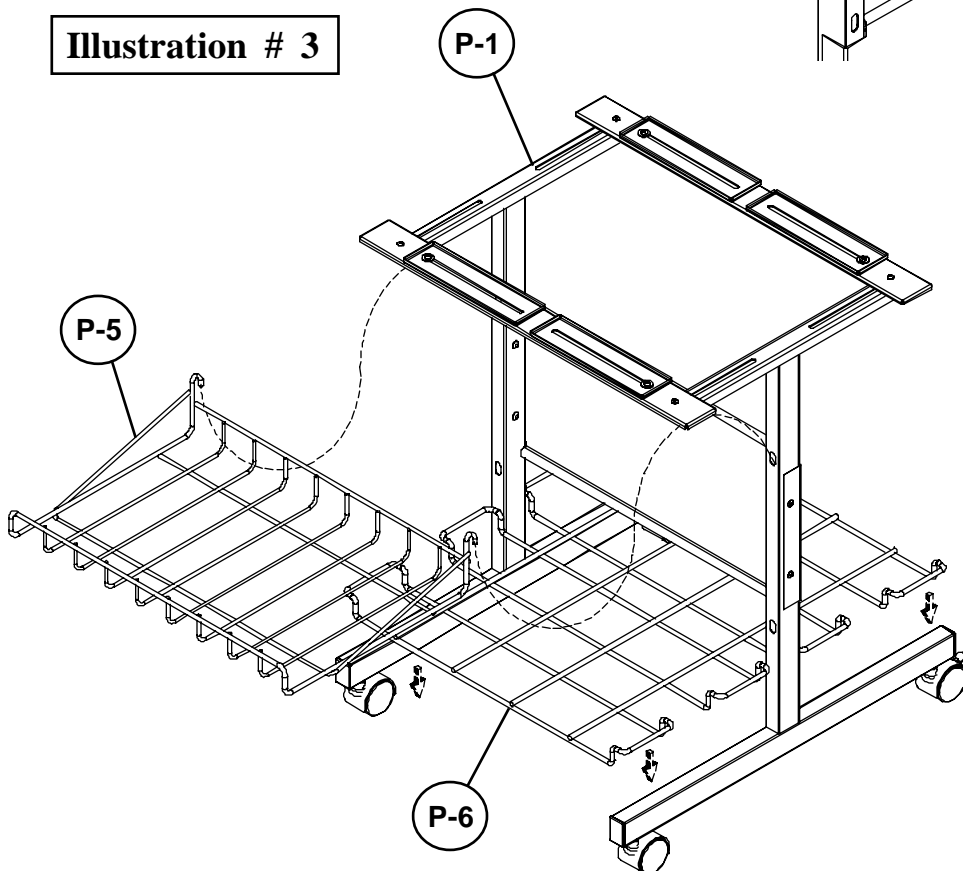

Illustration # 3



5. Install Forms Basket (P-5) in the holes on the Leg frame assy (P-1) as shown in illustration # 3.
6. Place Forms Rack (P-6) on lower part of Leg Frame Assembly (P-1).
7. Tighten all screws securely using the Allen Wrench (F).

1. FOR LARGE PRINTERS

Attach 2 Long Metal Plates (P-3) [through outer holes] and 4 Short Metal plates (P-4) to the Leg Frames using 4 Screws (A1), 4 Flat Washers (K) and 4 Wing Nuts (J).

Note: Long Metal Plates should be attached with Channel side down, and Short Metal Plates with the channel side up.

OPTION # 1

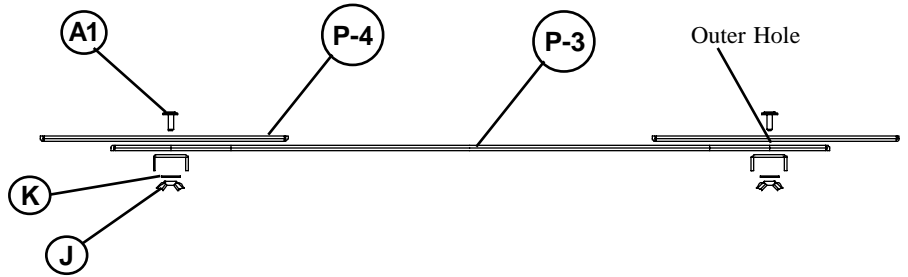

OPTION # 2

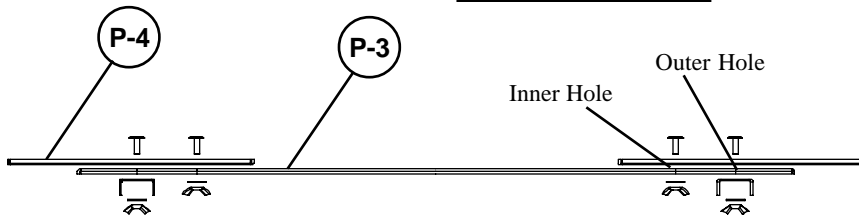

2. FOR EXTRA STABILITY WITH LARGE PRINTERS

Attach the Long Metal Plates (P-3) and Short Metal Plates (P-4) same as for the large Printers. Then attach Short Metal Plates through the inner holes on the Long Metal Plate using 4 Screws (A1), 4 Flat Washers (K) and 4 Wing Nuts (J) for added stability.

3. FOR NARROW PRINTERS

Attach 2 Long Metal Plates (P-3) [through outer holes] to the Leg Frames using 4 Screws (A), 4 Flat Washers (K) and 4 Wing Nuts (J).

Then attach 4 Short Metal Plates (P-4) through the inner holes on the Long Metal Plate using 4 Screws (A1), 4 Flat Washers (K) and 4 Wing Nuts (J).

OPTION # 3

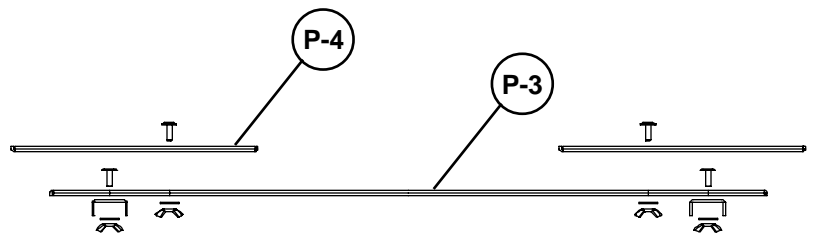

Important

The Balt product you have purchased is guaranteed against material and workmanship defects.

This guarantee extends 1 year from date of purchase. Should this product fail to function satisfactorily under normal use due to defect or imperfection, the defective part or product will be replaced.

Damage caused by common carriers during shipment is not included in this guarantee.

This guarantee sets forth all applicable guarantees and remedies. No other warranty, expressed or implied shall apply.

Failure to follow instructions found in Important Information Section of Owner Sheet shall void the guarantee.

Consequential or incidental damages and or costs are not refundable.

**Should you require assistance during assembly,
please call our Customer Service Department
Monday - Friday 8 a.m. - 5 p.m. Central Standard Time
Toll-Free Customer Service 1-800-749-2258**