

**BALT**<sup>®</sup>

**KAT-21**  
**Dual Laser Printer Stand**

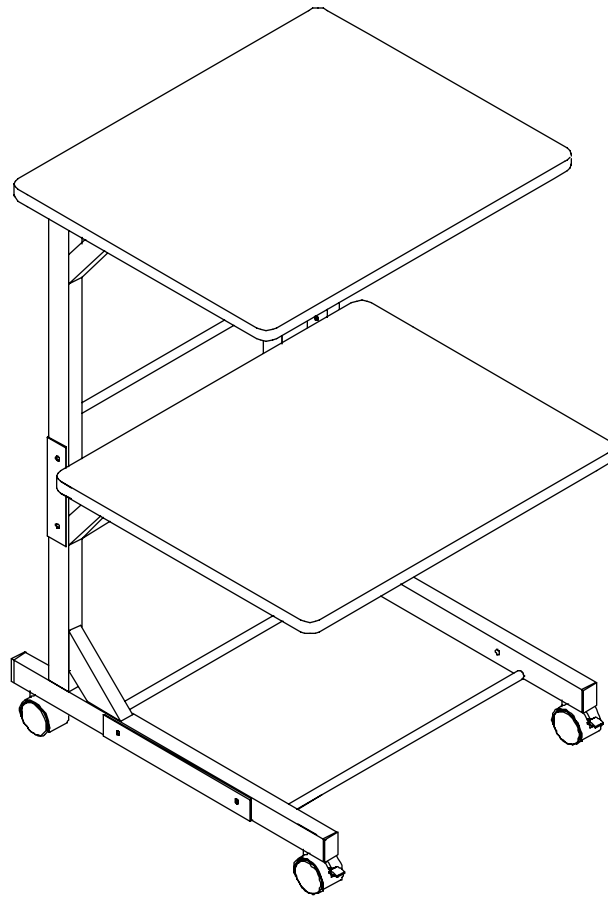









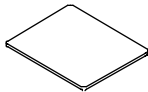

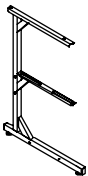

**Assembly Instructions**

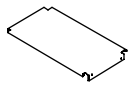
# Dual Laser Printer Stand KAT-21

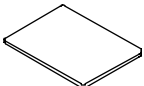
## Parts List

## Hardware List

Part	Drawing	Description	Qty	Drawing	Description	Qty
P-1		Top Panel	1 EA	A	 Flat Head Screw	16 EA
P-2		Leg Assembly	2 EA	B	 Interior Threaded Post	8 EA
P-3		Back Stability Panel	1 EA	C	 Leveling Feet	4 EA
P-4		Bottom Stability Panel	1 EA	D	 2" Locking Casters (for Front)	2 EA
P-5		Middle Shelf	1 EA	E	 2" Casters(for Back)	2 EA
				F	 Allen Wrench	1 EA
				G	 Caster Wrench	1 EA
				H	 Cable Clips	4 EA

**To Assemble:** (For convenience Printer Platforms may be installed with unit turned up-side-down.)

- 1.) Identify and Separate all the Parts and Hardware.
- 2.) Attach Bottom Stability Panel (P-4) to 2 Leg Assemblies (P-2) using 4 Screws (A) and 4 Interior Threaded Posts (B).
- 3.) Attach Back Stability Panel (P-3) to the 2 Leg Assemblies (P-2) using 4 Screws (A) and 4 Interior Threaded Posts (B).
- 4.) Attach Top Printer Platform (P-1) to the 2 Leg Assemblies (P-2) using 4 Screws (A).
- 5.) Attach Middle Shelf (P-5) to the 2 Leg Assemblies (P-2) using 4 Screws (A).
- 6.) Attach 4 Leveling Feet (C) or Casters to the Leg assemblies. [If casters, 2 Locking casters (D) in the front, and 2 casters (E) in the back. Tighten the casters using Caster wrench (G).
- 7.) Tighten all the screws securly using the Allen wrench.

### Important Information:

Do not use unless all screws are tight. At least every six months, check all screws to be sure they are tight. If parts are missing, broken, damaged, or worn, stop use of the product until repairs are made by your dealer using factory authorized parts.



## KAT-21 Dual Laser Printer Stand Assembly Diagram

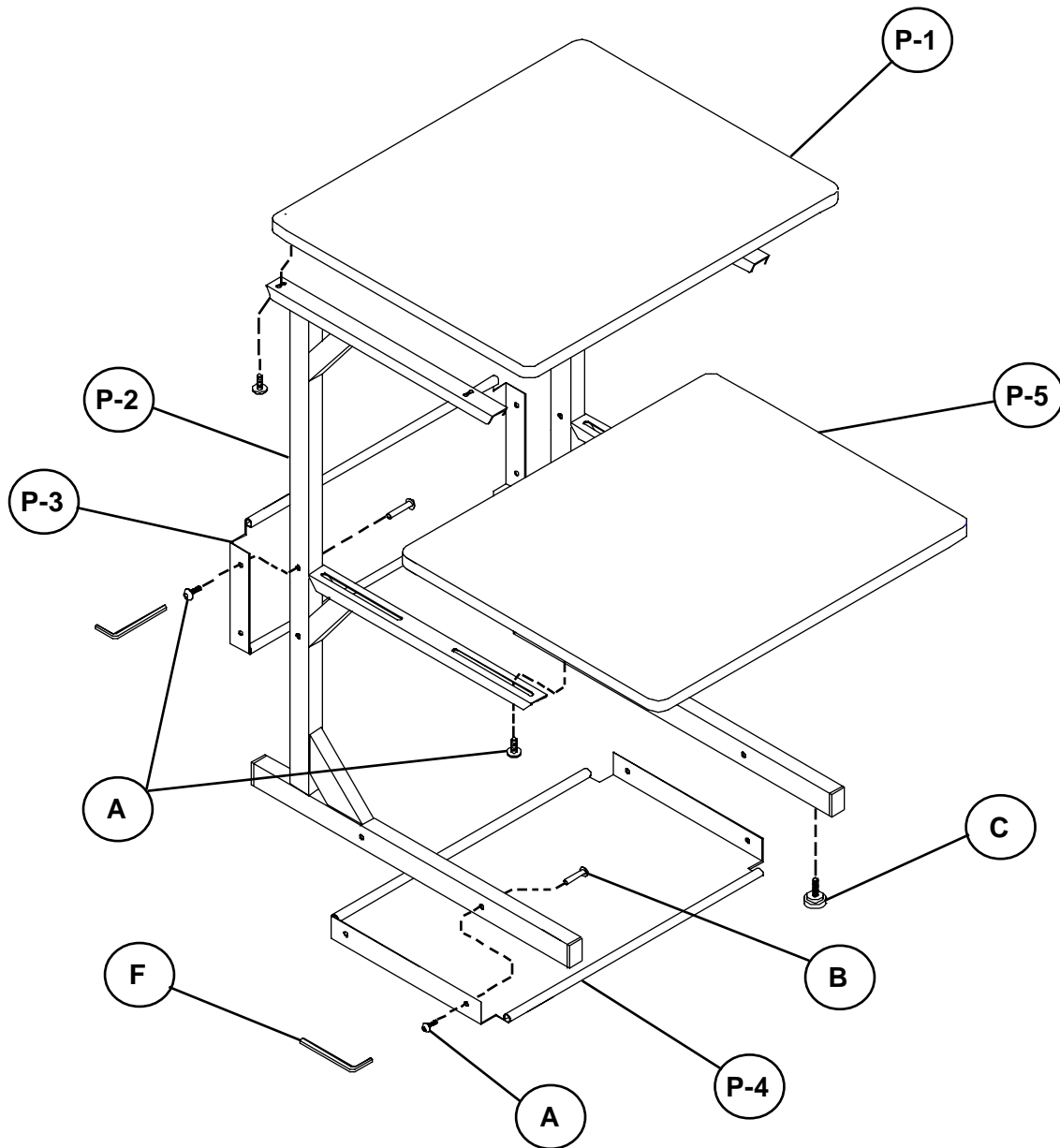

**Note:** It is recommended that when attaching stability panels, loosely tighten until all four screws and interior threaded posts are positioned before fully tightening with Allen Wrench.

## **Important**

The Balt product you have purchased is guaranteed against material and workmanship defects. This guarantee extends 1 year from date of purchase.

Should this product fail to function satisfactorily under normal use due to defect or imperfection, the defective part or product will be replaced. Damage caused by common carriers during shipment is not included in this guarantee.

**This guarantee sets forth all applicable guarantees and remedies. No other warranty, expressed or implied shall apply. Failure to follow instructions found in Important Information Section of Owner Sheet shall void the guarantee. Consequential or incidental damages and or costs are not refundable.**

Toll-Free Customer Service

**1-800-749-2258**

***Should you require assistance during assembly,  
please call our Customer Service Department  
Monday - Friday 8 a.m. - 5 p.m.  
Central Standard Time***