

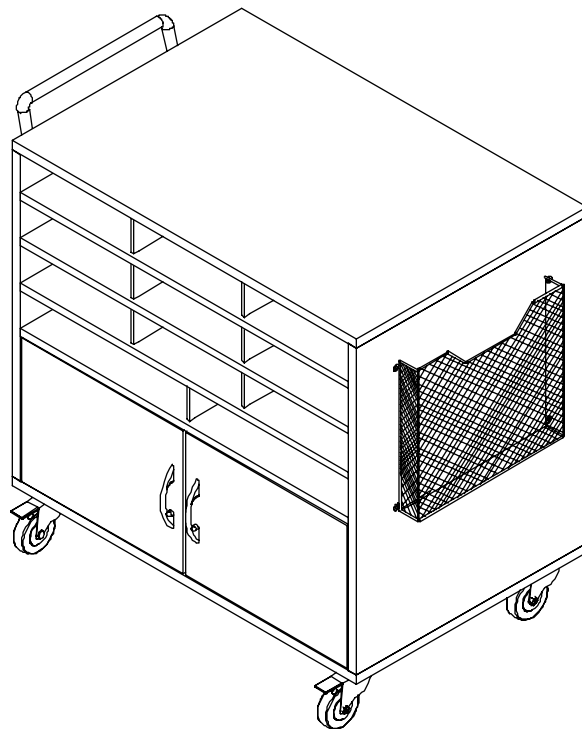

BLT-27503











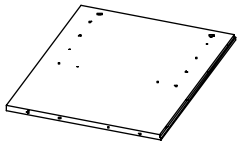

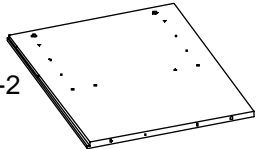
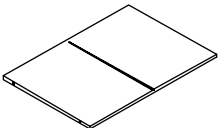

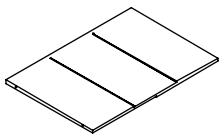

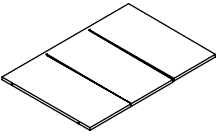

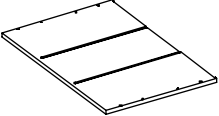

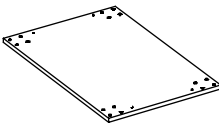

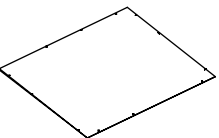

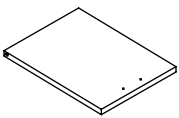
Dual Fax Stand W/Paper Storage

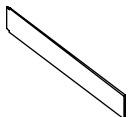

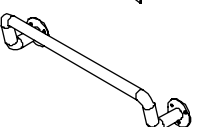
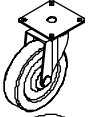
Assembly Instructions

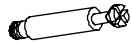
BLT-27503

Dual Fax Stand w/Paper Storage

Part	Drawing	Description	Qty	Part	Drawing	Description	Qty
P-1		Left Side Panel	1 EA	P-12		Wire Basket	1 EA
P-2		Right Side Panel	1 EA	Hardware List			
P-3		Lower Shelf	1 EA	A		Screw M6 X 1/2"	16 EA
P-4		Middle Shelf	1 EA	A1		#8 x 2" Wood Screw	4 EA
P-5		Upper Shelf	2 EA	A2		#6 x 1 1/4" Wood Screw	4 EA
P-6		Top Panel	1 EA	A3		#4 x 5/8" Wood Screw	26 EA
P-7		Bottom Panel	1 EA	A4		#4 x 5/8" Wood Screw SMALLER HEAD	4 EA
P-8		Back Panel	1 EA	B		Flat Washer	4 EA
P-9		Door	2 EA	C		Magnetic 2 Door Catch	1EA
P-10		Divider Panel	7 EA	D		3" Locking Caster (for front)	2 EA
P-11		Handle	1 EA	E		3" Caster (for Back)	2 EA
				F		Cam Lock	8 EA
				G		Cam Post	8 EA
				H		Spring Button	4 EA
				J		Wood Dowel	24 EA
				K		Allen Wrench	1 EA
				L		Door Handle	2 EA

BLT-27503 Assembly Diagram



Tools required: Phillips Head Screwdriver

To Assemble:

1. Identify and Separate all the Parts and Hardware.
2. Place the Left Side Panel (P-1) with the Pre-drilled holes facing up and install 2 Cam Locks (F) into the large holes in each Panel as shown in illustration # 1.
3. Install 8 each Wood Dowels (J) into the drilled holes as shown in illustration # 2.
4. Install 2 each Cam Posts (G) in the 2 threaded insert nuts (Pre-installed) as shown in illustration # 2.
5. Repeat Steps 1-4 for the Right Side Panel (P-2)

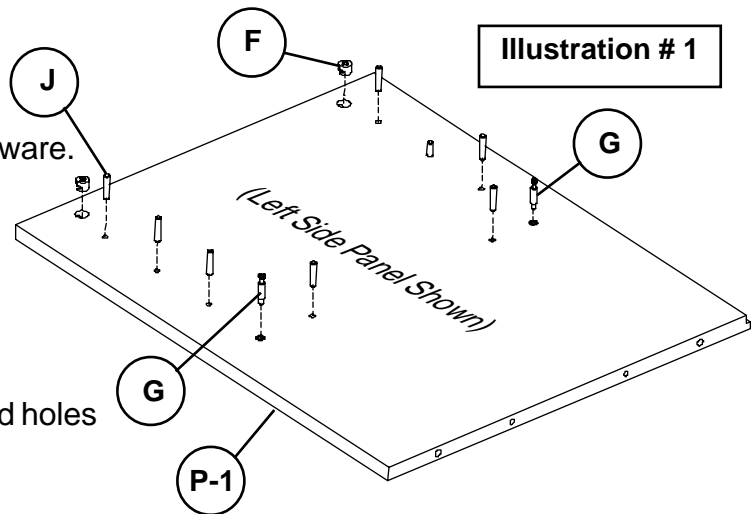
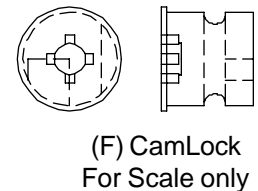
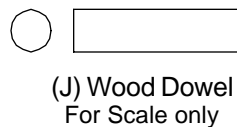
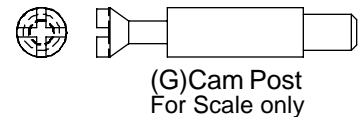

Illustration # 1



6. Place the Lower shelf (P-3) with the Holes facing up. Attach 1 Magnetic Door Catch (C) to the Lower shelf (P-3) using 4 each Wood Screws (A4) as shown in illustration # 2.
7. Install 4 each Cam Locks (F) into the large holes in each Panel as shown in illustration # 2.

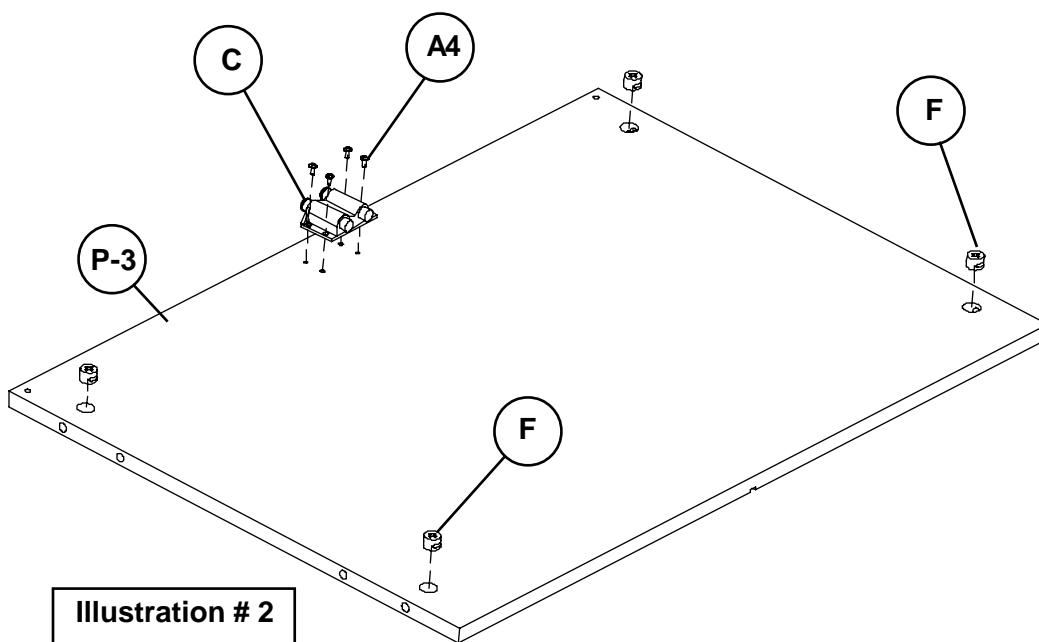
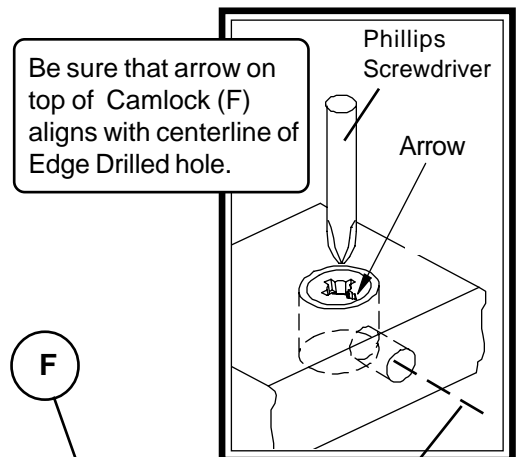
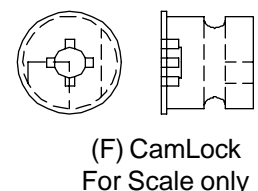
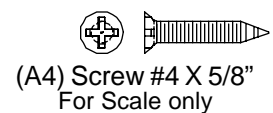

Illustration # 2



Centerline of Edge Drilled hole.



8. Place the Top Panel (P-6) with the Holes facing up. Install 4 each Wood Dowels (J) into the drilled holes as shown in illustration # 3.

Illustration #3

9. Install 4 each Cam Posts (G) in the 4 threaded insert nuts (Pre-installed) as shown in illustration # 3.



(J) Wood Dowel
For Scale only

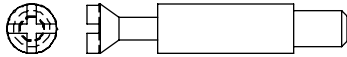

(G) Cam Post
For Scale only

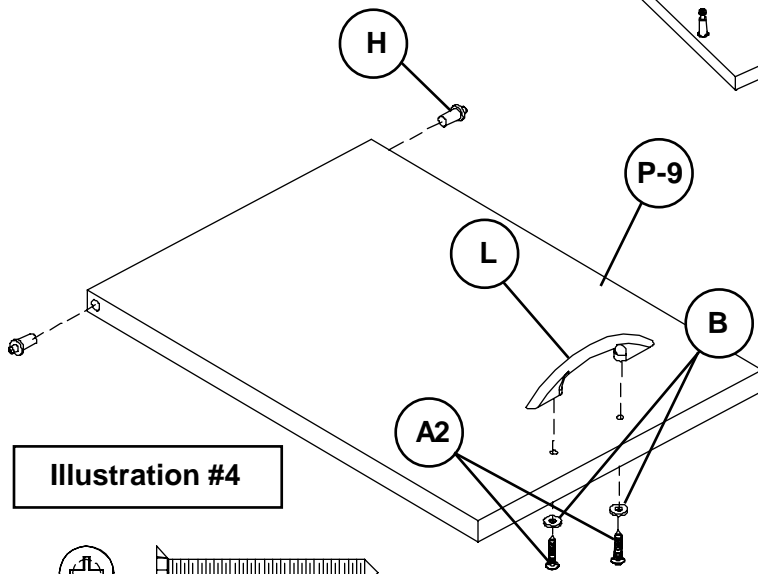
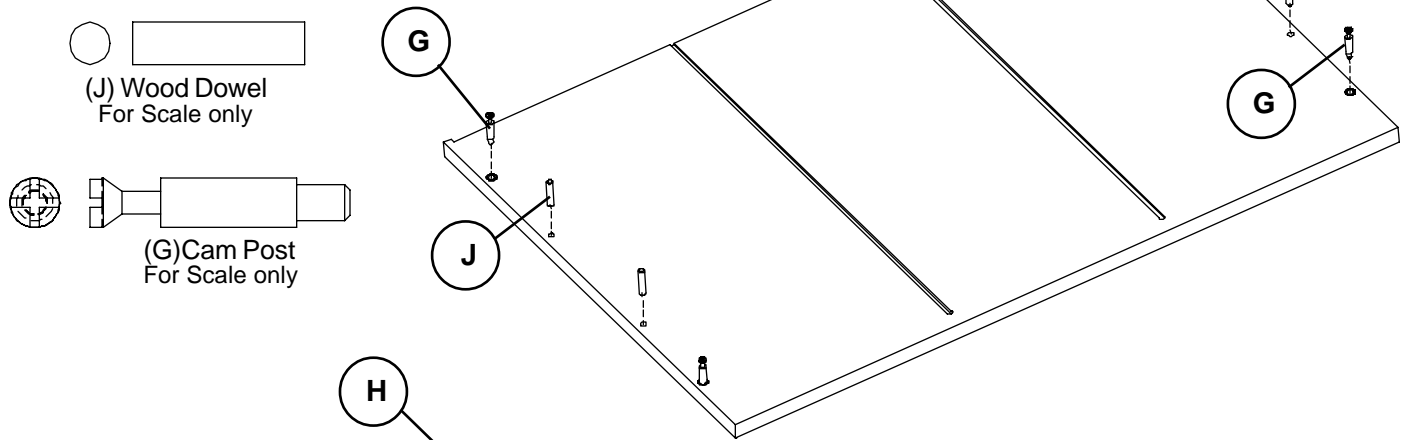

Illustration #4



(A2) Screw #6 X 1 1/4"
For Scale only

10. Insert 2 each Spring Buttons (H) in the top and bottom of door (P-9) as shown in illustration # 4.

11. Attach Door Handle (L) to Door (P-9) using 2 each Flat Washers (B) & 2 each screws (A2).

12. Repeat steps 10&11 for second Door (P-9).

13. Place the Bottom Panel (P-7) with the Holes facing up. Install 4 each Wood Dowels (J) into the drilled holes as shown in illustration # 5.

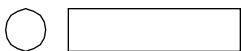

(J) Wood Dowel
For Scale only

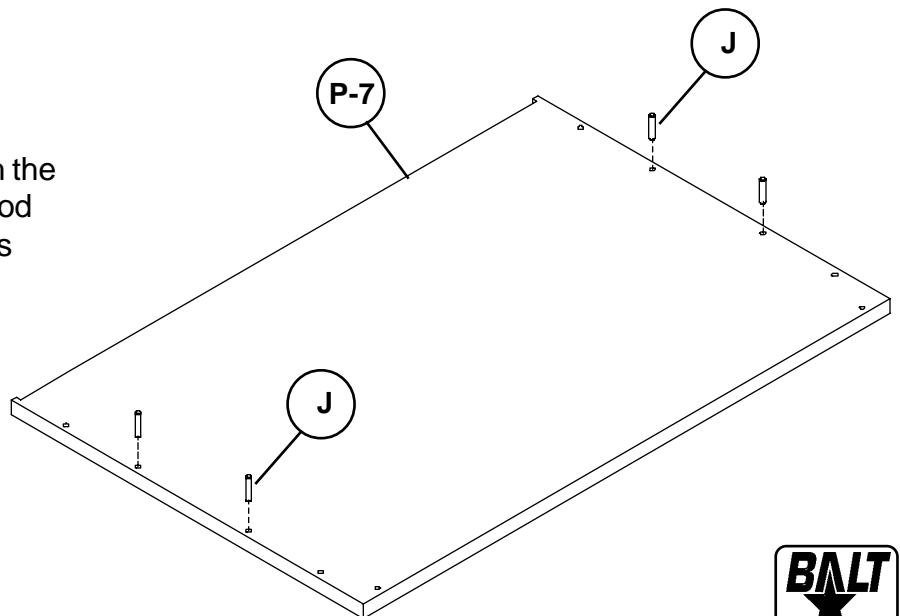
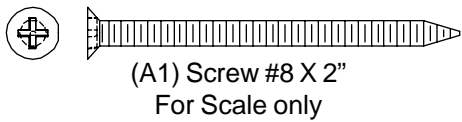
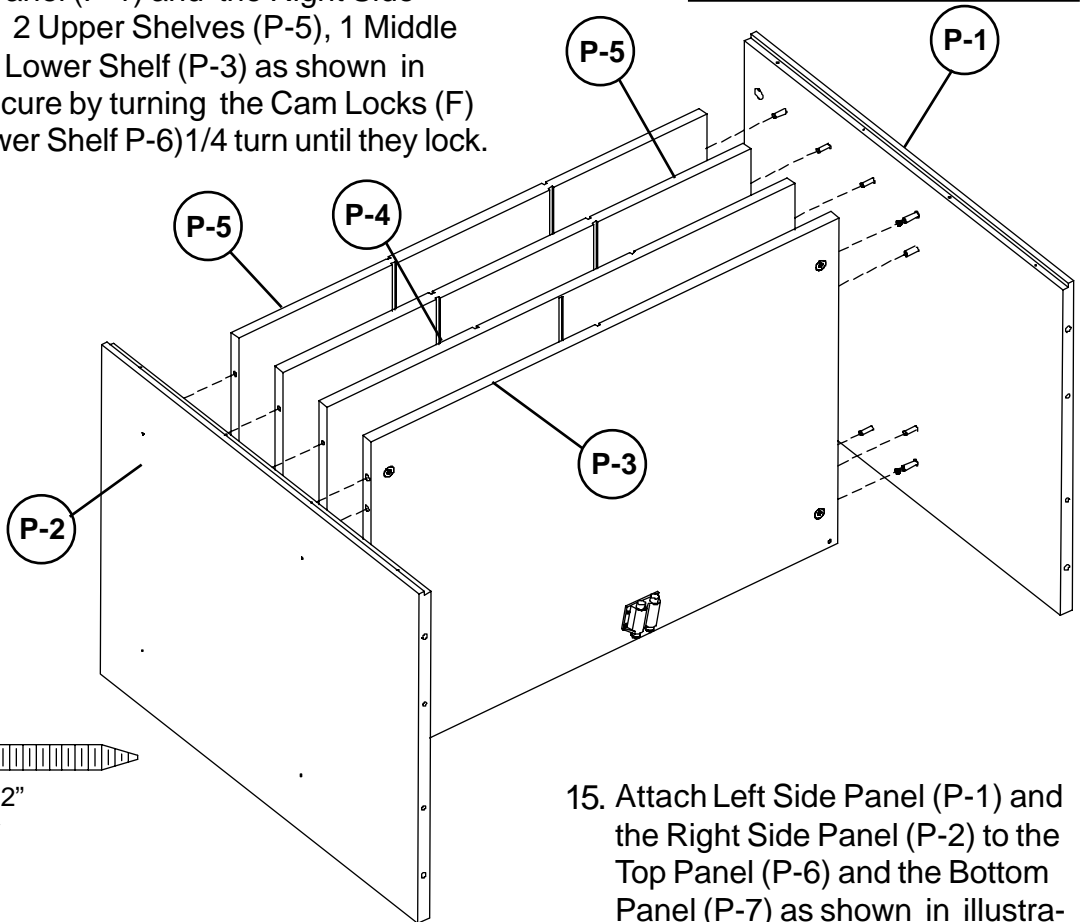

Illustration #5



14. Attach Left Side Panel (P-1) and the Right Side Panel (P-2) to the 2 Upper Shelves (P-5), 1 Middle Shelf (P-4), and 1 Lower Shelf (P-3) as shown in illustration # 6. Secure by turning the Cam Locks (F) (located in the Lower Shelf P-6) 1/4 turn until they lock.

Illustration #6



15. Attach Left Side Panel (P-1) and the Right Side Panel (P-2) to the Top Panel (P-6) and the Bottom Panel (P-7) as shown in illustration # 7. Secure by turning the Cam Locks (F) 1/4 turn until they lock.

16. Attach the Bottom Panel (P-7) to the Left Side Panel (P-1) and the Right Side Panel (P-2) using 4 each Screws (A1) as shown in illustration # 7.

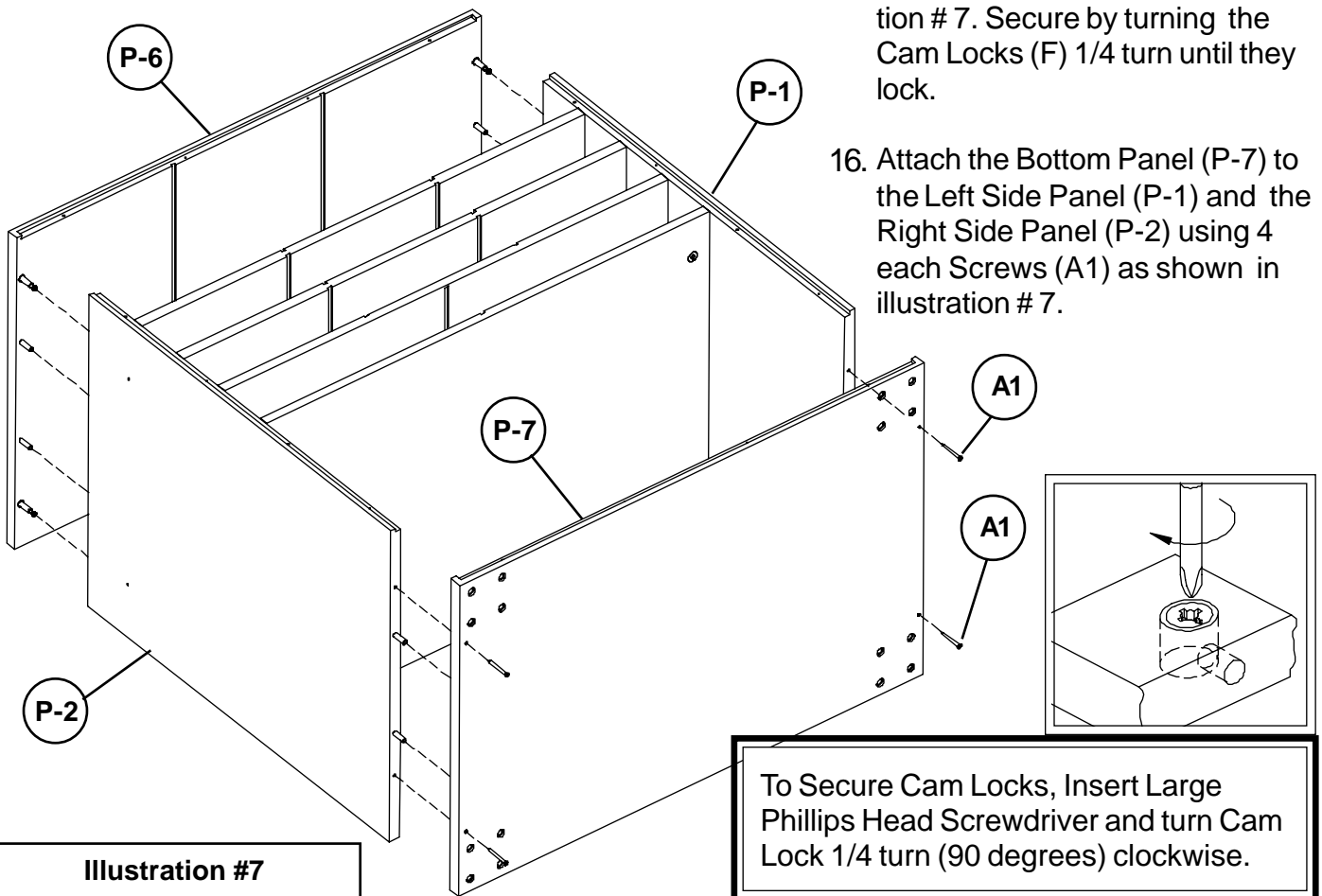

Illustration #7

To Secure Cam Locks, Insert Large Phillips Head Screwdriver and turn Cam Lock 1/4 turn (90 degrees) clockwise.

Illustration #8

17. Attach 2 Locking Plate Casters (D) and 2 Plate Casters (E) to the Bottom Platform (P-7) using 16 screws (A). Tighten (A) Screws using Allen Wrench (K).

18. Insert 7 each Divider Panels (P-10) into the grooves in the Top Panel (P-6), the 2 Upper Shelves (P-5), 1 Middle Shelf (P-4), and 1 Lower Shelf (P-3) as shown in illustration # 8.

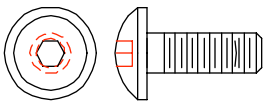

(A) Screw M6 X 1/2"
For Scale only

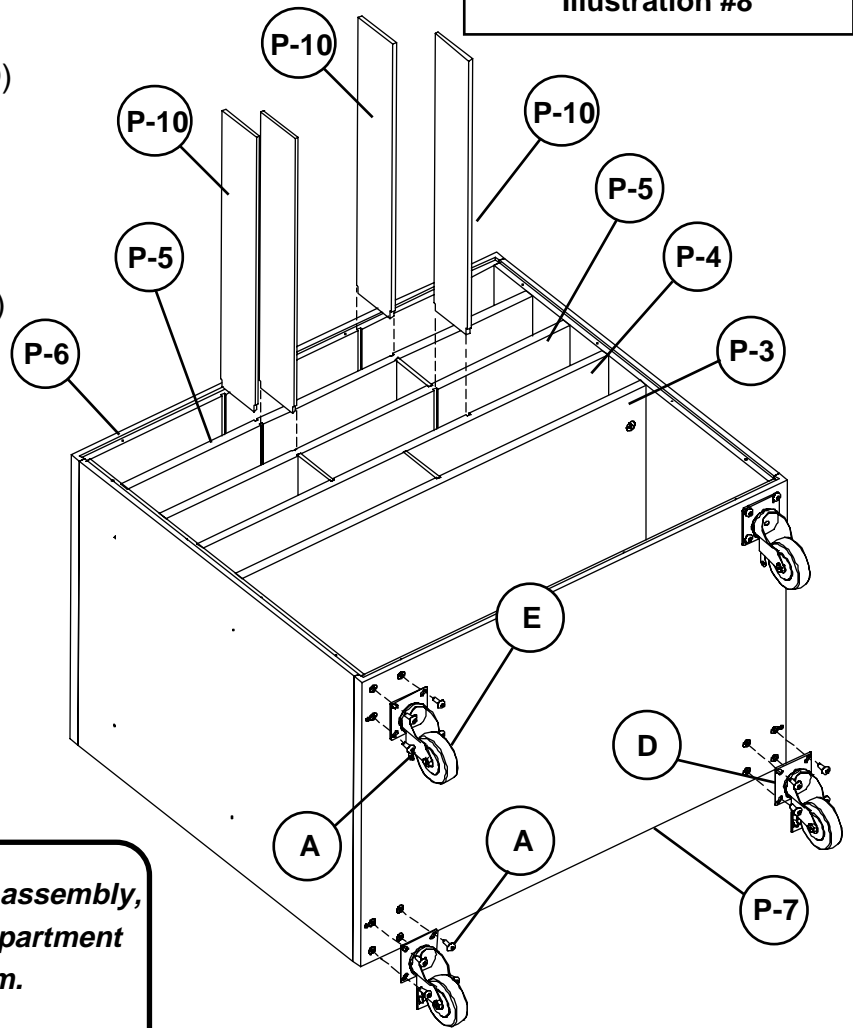

**Should you require assistance during assembly,
please call our Customer Service Department
Monday - Friday 8 a.m. - 5 p.m.
Central Standard Time
Toll-Free Customer Service
1-800-749-2258**

19. Insert Back Panel (P-8) in the groove in the Left Side Panel (P-1), the Right Side Panel (P-2), and the Top Panel (P-6) as shown in illustration #9. Secure by inserting 16 Screws (A3) into the Top Panel (P-6), the Left Side Panel (P-1), the Right Side Panel (P-2), and the Bottom Platform (P-7).



(A3) Screw #4 X 5/8"
For Scale only

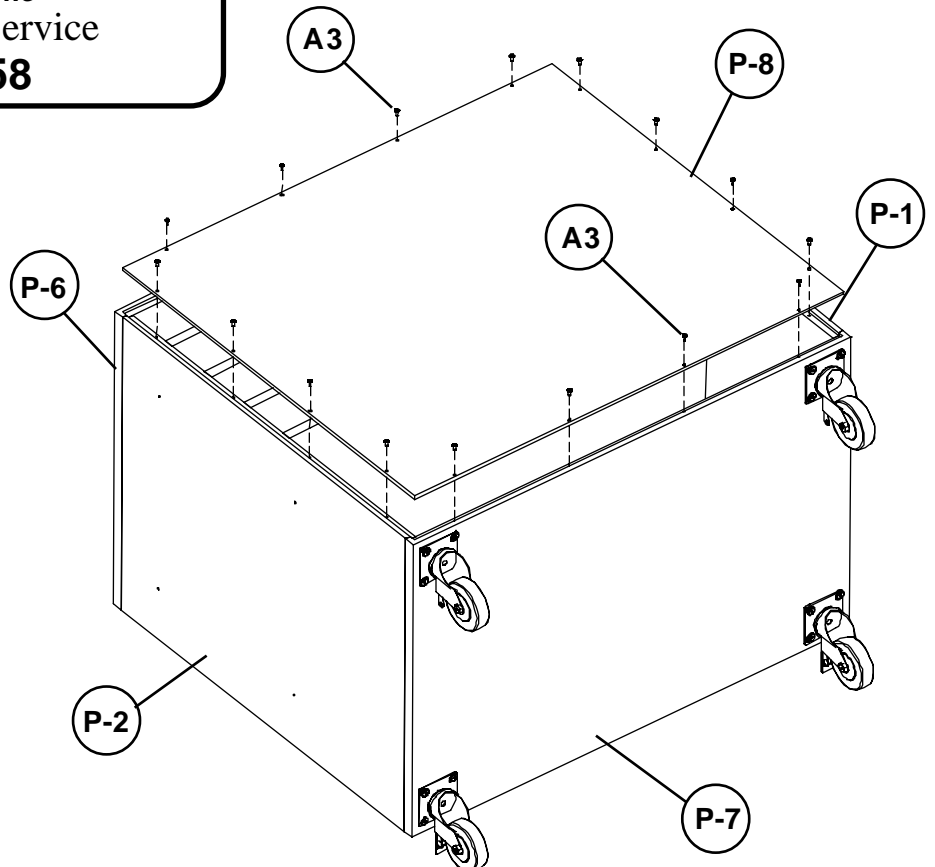
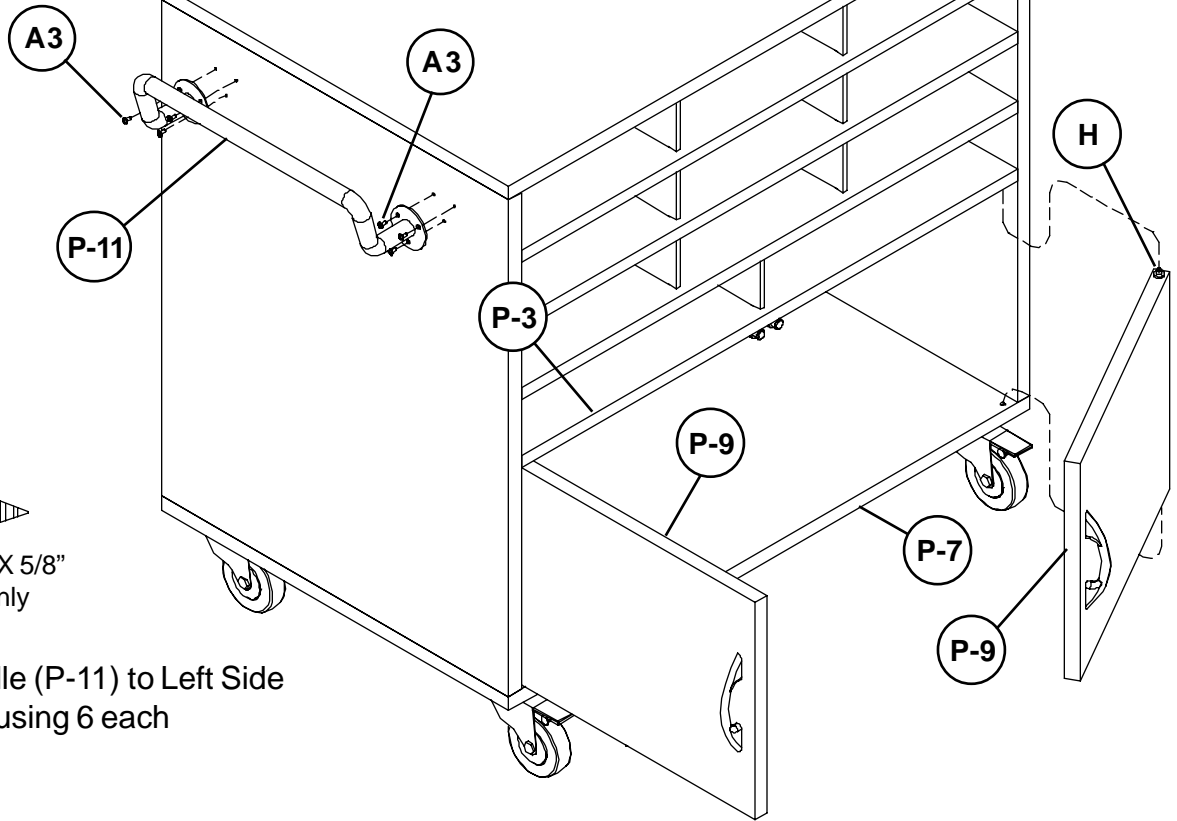

Illustration #9

Illustration #10

20. To Install the doors (P-9), insert the end of Spring Buttons (H) into the holes in the Bottom Panel (P-7) and the Lower Shelf (P-3) as shown in illustration # 10. [Insert bottom of Door First]



(A3) Screw #4 X 5/8"
For Scale only

21. Attach Handle (P-11) to Left Side Panel (P-1) using 6 each (A-3) screw.

Illustration #11

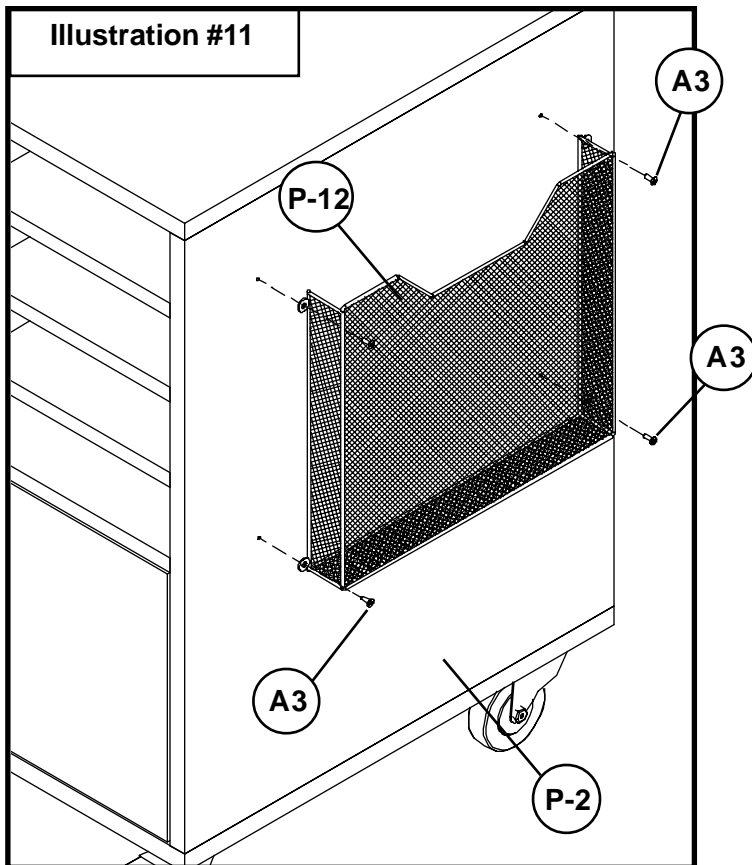

22. Attach the Wire Basket (P-12) to the Right Side Panel (P-2) using 4 each screws (A3) as shown in illustration #11.

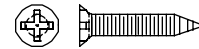

(A3) Screw #4 X 5/8"
For Scale only

Missing Parts or UPS Damaged Parts

For Your Convenience you can
EMAIL us at

furniture@baltinc.com

24HOURS 7 DAYS A WEEK

Do not use unless all screws are tight.
At least every six months, check all
screws to be sure they are tight. If
parts are missing, broken, damaged, or
worn, stop use of the product until
repairs are made by your dealer using
factory authorized parts.