

BALT[®]

CPU-MTBG
Mobile CPU Holder

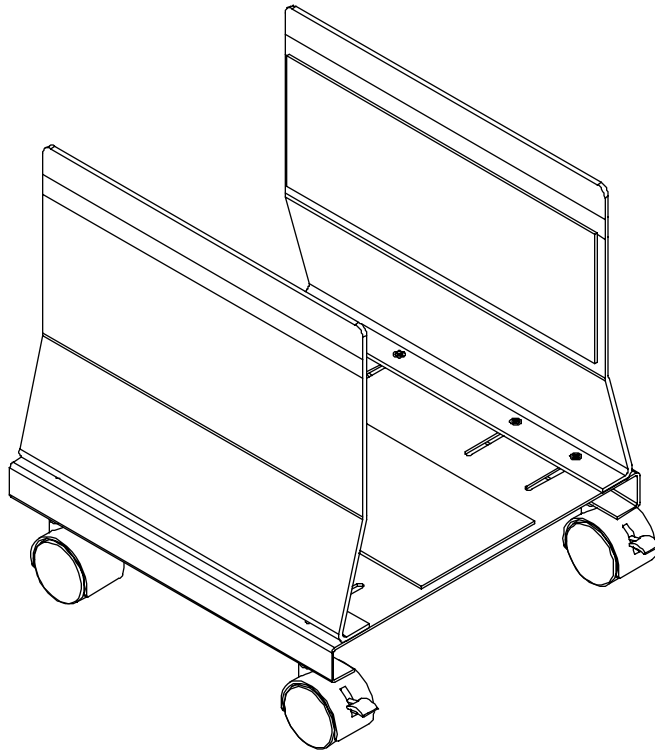

Assembly Instructions

CPU-MTBG

Mobile CPU Holder







Part	Drawing	Description	Qty	Part	Drawing	Description	Qty
P1		CPU Base	1 EA	Hardware List			
P2		CPU Support	2 EA	A		Phillips Head Screw 5/8"	8 EA
P3		Adhesive Foam Pads	3 EA	B		Hex Nut -small	8 EA
<p style="text-align: center;">Should you require assistance during assembly, please call our Customer Service Department Monday - Friday 8 a.m. - 5 p.m. Central Standard Time 1-800-749-2258</p>				C		Flat Washer	8 EA
				D		Hex Nut - large	4 EA
				E		Locking Caster 1-1/2"	2 EA
				F		Caster 1-1/2"	2 EA
				G		Caster Wrench	1 EA

Illustration # 1

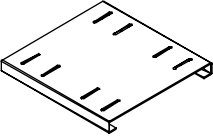
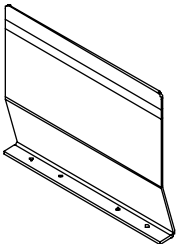
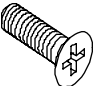
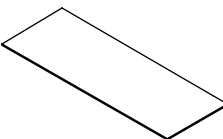
READ THROUGH INSTRUCTIONS FROM BEGINNING TO END BEFORE STARTING TO ASSEMBLE UNIT.

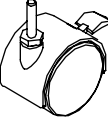
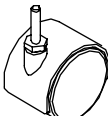

1. Identify and Separate all the Parts and Hardware.

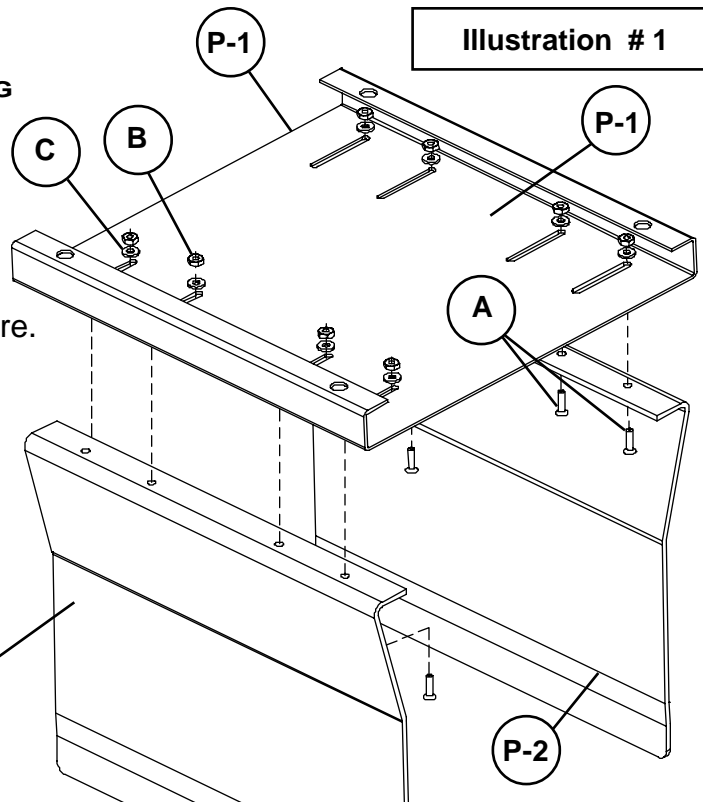
2. Attach 2 each CPU Supports (P-2) to CPU Base (P-1) using 8 each screws (A), 8 each Flat Washers (C), and 8 each Hex Nuts(B) as shown in illustration #1.

Missing Parts or UPS Damaged Parts

For Your Convenience you can
EMAIL us at
furniture@baltinc.com
24HOURS 7 DAYS A WEEK

CPU-WRITE Assembly Diagram

BALT®

3. Attach 2 Locking Casters (E) to one end of CPU Base (P-1) using 2 each Large Hex Nuts (D). Attach 2 Casters (F) to the other end of CPU Base (P-1) using 2 each Large Hex Nuts (D). Tighten all Casters using Caster Wrench (G).

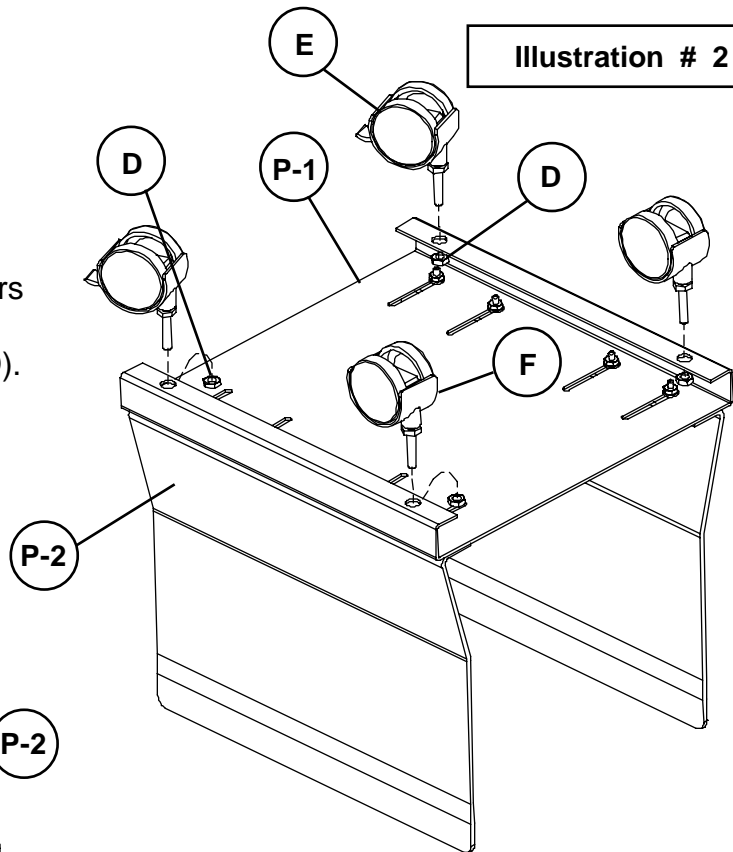
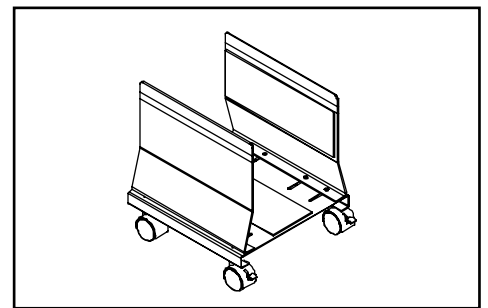
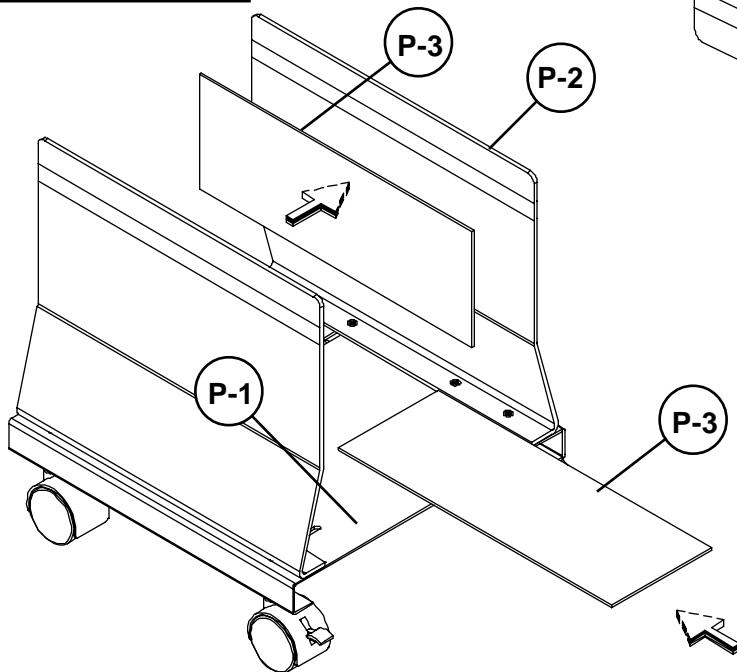

Illustration # 3



4. Attach 2 Adhesive Foam Pads (P-3) to 2 each CPU Supports (P-2) as shown in illustration #3. Attach 1 Adhesive Foam Pad (P-3) to CPU Base (P-1) as shown in illustration #3.

Do not use unless all screws are tight. At least every six months, check all screws to be sure they are tight. If parts are missing, broken, damaged, or worn, stop use of the product until repairs are made by your dealer using factory authorized parts.