

BALT[®]

WOW

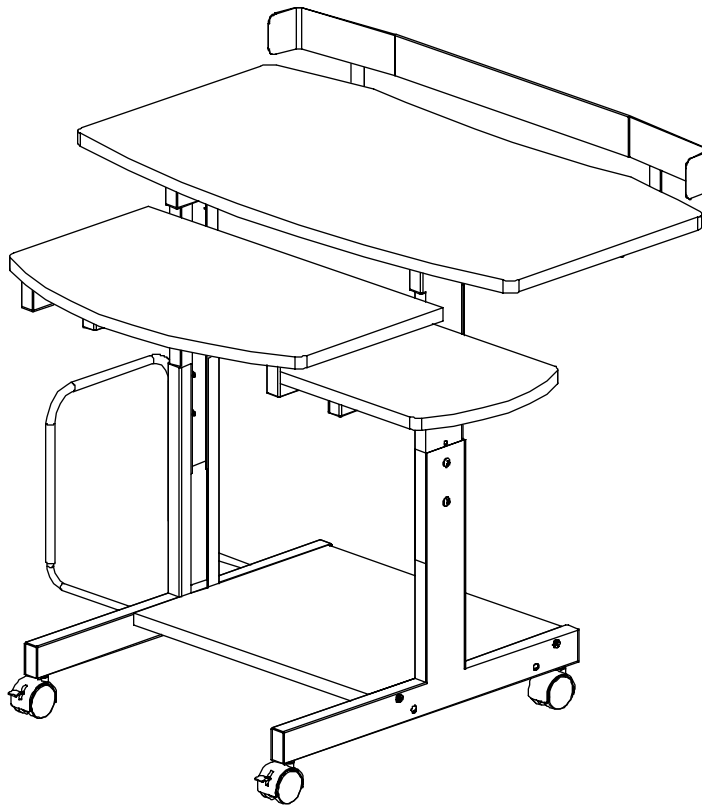









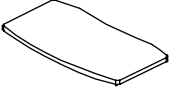
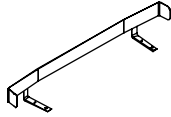
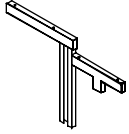





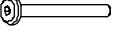





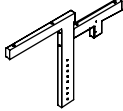
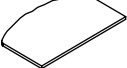
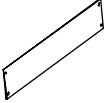

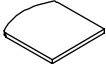

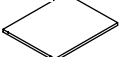







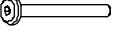





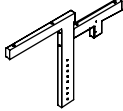
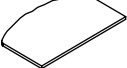
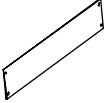

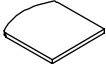

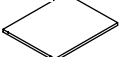







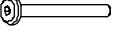

Workstation On Wheels

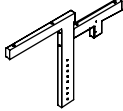
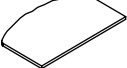
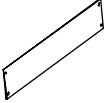

Assembly Instructions

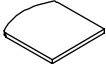
Wow

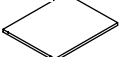
Workstation on Wheels

Part	Drawing	Description	Qty	Part	Drawing	Description	Qty																																																																																								
P-1		Top Platform 35½x19¾"	1 EA	P-13		Optional Monitor Rail	1 EA																																																																																								
P-2		Right Upper Insert	1 EA	<div style="border: 1px solid black; border-radius: 15px; padding: 10px;"> <h3 style="text-align: center;">Hardware List</h3> <table border="0"> <tr> <td>A</td> <td></td> <td>Black Plastic Spacer</td> <td>2 EA</td> </tr> <tr> <td>B</td> <td></td> <td>Hex Nut</td> <td>4 EA</td> </tr> <tr> <td>C</td> <td></td> <td>Flat Washer</td> <td>4 EA</td> </tr> <tr> <td>D</td> <td></td> <td>Square Nut</td> <td>4 EA</td> </tr> <tr> <td>E</td> <td></td> <td>9/16" Socket Head Screw</td> <td>11 or 15 EA</td> </tr> <tr> <td>F</td> <td></td> <td>1-7/8" Socket Screw</td> <td>4 EA</td> </tr> <tr> <td>G</td> <td></td> <td>2-3/8" Socket Screw</td> <td>8 EA</td> </tr> <tr> <td>H</td> <td></td> <td>1/2" Sheet Metal Screw</td> <td>4 EA</td> </tr> <tr> <td>J</td> <td></td> <td>2" Locking Caster (for front)</td> <td>2 EA</td> </tr> <tr> <td>K</td> <td></td> <td>2" Caster (for back)</td> <td>2 EA</td> </tr> <tr> <td>L</td> <td></td> <td>Allen Wrench</td> <td>1 EA</td> </tr> <tr> <td>M</td> <td></td> <td>Caster Wrench</td> <td>1 EA</td> </tr> </table> </div> <tr> <td>P-3</td> <td></td> <td>Left Upper Insert</td> <td>1 EA</td> </tr> <tr> <td>P-4</td> <td></td> <td>Keyboard Shelf</td> <td>1 EA</td> </tr> <tr> <td>P-5</td> <td></td> <td>Stability Panel</td> <td>1 EA</td> </tr> <tr> <td>P-6</td> <td></td> <td>Folding Bracket</td> <td>1 EA</td> </tr> <tr> <td>P-7</td> <td></td> <td>Mouse Platform</td> <td>1 EA</td> </tr> <tr> <td>P-8</td> <td></td> <td>Left Leg Receiver</td> <td>1 EA</td> </tr> <tr> <td>P-9</td> <td></td> <td>Right Leg Receiver</td> <td>1 EA</td> </tr> <tr> <td>P-10</td> <td></td> <td>Accessory Platform</td> <td>1 EA</td> </tr> <tr> <td>P-11</td> <td></td> <td>CPU Sleeve</td> <td>1 EA</td> </tr> <tr> <td>P-12</td> <td></td> <td>CPU Rod</td> <td>2 EA</td> </tr>				A		Black Plastic Spacer	2 EA	B		Hex Nut	4 EA	C		Flat Washer	4 EA	D		Square Nut	4 EA	E		9/16" Socket Head Screw	11 or 15 EA	F		1-7/8" Socket Screw	4 EA	G		2-3/8" Socket Screw	8 EA	H		1/2" Sheet Metal Screw	4 EA	J		2" Locking Caster (for front)	2 EA	K		2" Caster (for back)	2 EA	L		Allen Wrench	1 EA	M		Caster Wrench	1 EA	P-3		Left Upper Insert	1 EA	P-4		Keyboard Shelf	1 EA	P-5		Stability Panel	1 EA	P-6		Folding Bracket	1 EA	P-7		Mouse Platform	1 EA	P-8		Left Leg Receiver	1 EA	P-9		Right Leg Receiver	1 EA	P-10		Accessory Platform	1 EA	P-11		CPU Sleeve	1 EA	P-12		CPU Rod	2 EA
A		Black Plastic Spacer	2 EA																																																																																												
B		Hex Nut	4 EA																																																																																												
C		Flat Washer	4 EA																																																																																												
D		Square Nut	4 EA																																																																																												
E		9/16" Socket Head Screw	11 or 15 EA																																																																																												
F		1-7/8" Socket Screw	4 EA																																																																																												
G		2-3/8" Socket Screw	8 EA																																																																																												
H		1/2" Sheet Metal Screw	4 EA																																																																																												
J		2" Locking Caster (for front)	2 EA																																																																																												
K		2" Caster (for back)	2 EA																																																																																												
L		Allen Wrench	1 EA																																																																																												
M		Caster Wrench	1 EA																																																																																												
P-3		Left Upper Insert	1 EA																																																																																												
P-4		Keyboard Shelf	1 EA																																																																																												
P-5		Stability Panel	1 EA																																																																																												
P-6		Folding Bracket	1 EA																																																																																												
P-7		Mouse Platform	1 EA																																																																																												
P-8		Left Leg Receiver	1 EA																																																																																												
P-9		Right Leg Receiver	1 EA																																																																																												
P-10		Accessory Platform	1 EA																																																																																												
P-11		CPU Sleeve	1 EA																																																																																												
P-12		CPU Rod	2 EA																																																																																												

We recommend that you assemble this unit on a table.

Tools required: Phillips Head Screw Driver Adjustable Crescent Wrench

**Should you require assistance during assembly,
please call our Customer Service Department
Monday - Friday 8 a.m. - 5 p.m. Central Standard Time**

Toll-Free Customer Service

1-800-749-2258

Do not use unless all screws are tight. At least every six months, check all screws to be sure they are tight. If parts are missing, broken, damaged, or worn, stop use of the product until repairs are made by your dealer using factory authorized parts.

WOW - Assembly Diagram

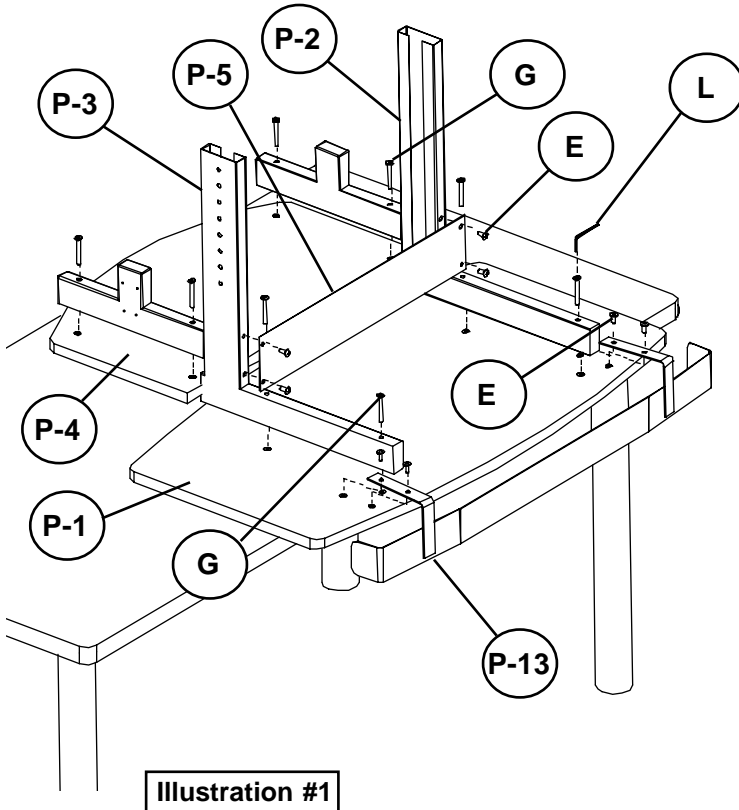

Illustration #1

1. Identify and Separate all the Parts and Hardware.
2. Place the Top panel (P-1) with the insert nuts facing up. Attach Right Upper Insert (P-2) and Left Upper Insert (P-3) using (4) G screws.
(Do not tighten the screws all the way)
3. Attach Optional Monitor Security Rail (P-13) to the Top Panel (P-1), using (4) E screws.
4. Attach Keyboard Shelf (P-4) to Left & Right Upper Inserts (P-3 & P-2) using (4) G screws.
5. Attach Stability Panel (P-5) to Left & Right Upper Inserts (P-3 & P-2) using (4) E screws.

6. Attach Folding Bracket (P-6) to Right Upper Insert (P-2) [Shown in illustration # 2] *(or Left Upper Insert (P-3))* using (2) H screws. Then Squeeze rounded mouse button and open the bracket into locked position as shown in illustraton #3 and secure the bracket with remaining (2) H screws.

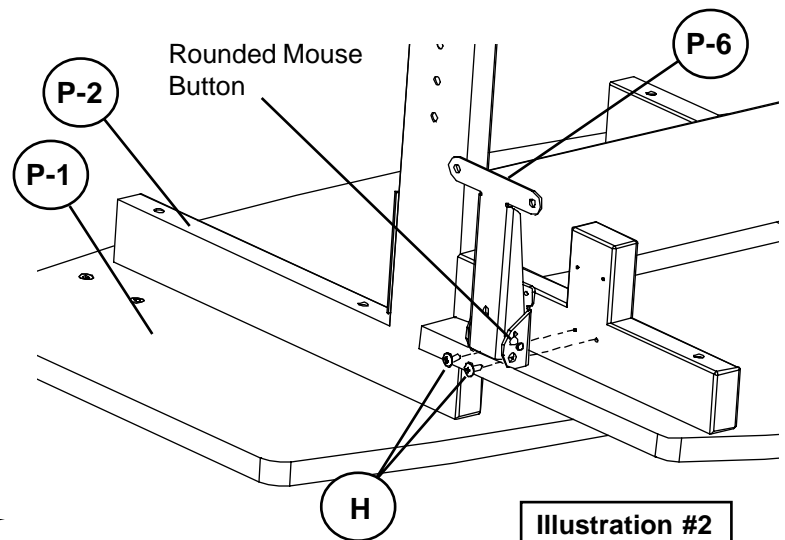

Illustration #2

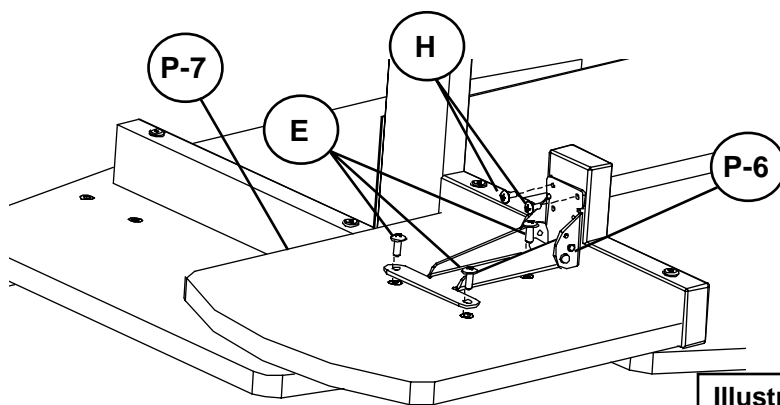
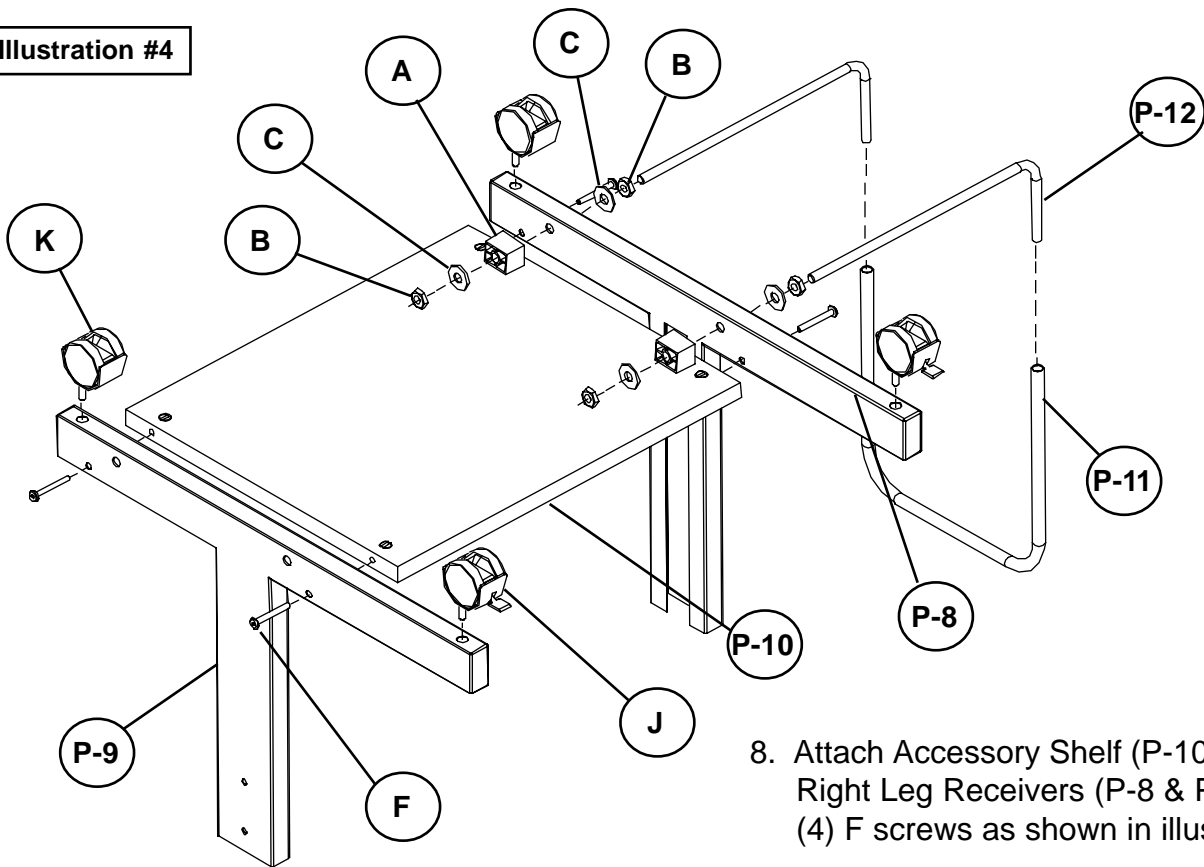

Illustration #3

7. Attach Mouse Pad (P-7) to the Folding Bracket (P-6) using (3) E screws.

Illustration #4



10. Attach (2) each CPU Rods (P-12) to the Left Leg Receiver (P-8) [opposite side from the Mouse Platform, shown in illustration # 4] (or Right Leg Receiver (P-9)). Secure each rod with (2) each B Hex nuts, (2) each C Flat Washers and (1) each A Black spacer. Slide CPU Sleeve over ends of CPU Rods as shown.

11. Slide the Upper Insert Assembly into the Lower Receiver Assembly and secure at the desired height with (4) each E Screws and (4) each D Square nuts (flat side of the nut should be next to the metal)

12. Tighten all screws Securely.

8. Attach Accessory Shelf (P-10) to Left & Right Leg Receivers (P-8 & P-9) using (4) F screws as shown in illustration # 4.

9. Attach (2) J Locking Casters to the front of the Leg receivers and (2) K Casters to the back of the Leg Receivers.

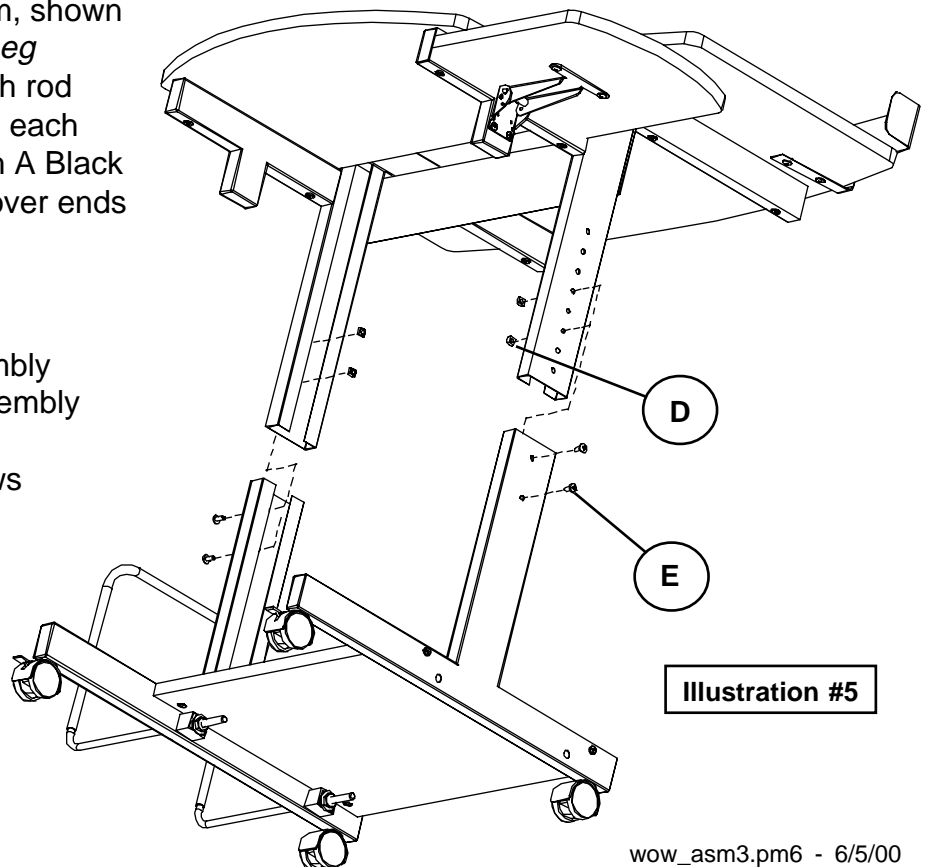

Illustration #5