

BALT[®]

LS-24

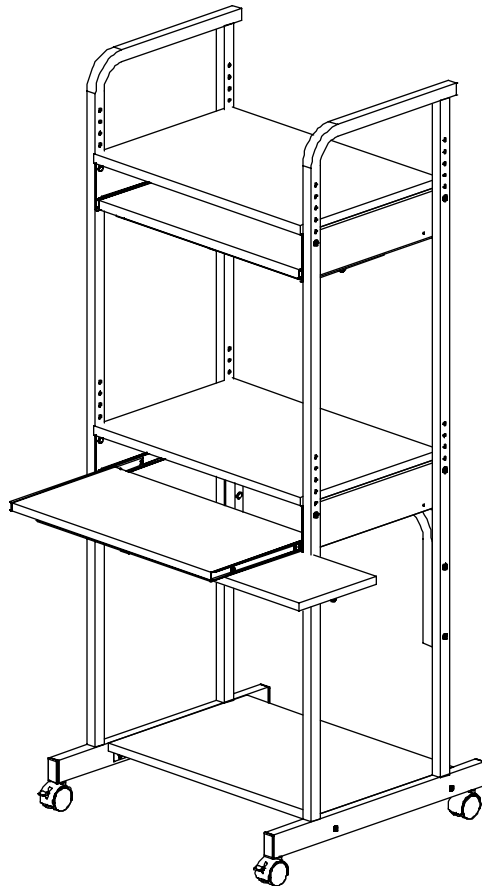









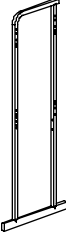

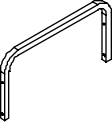

Adjustable Lan Station

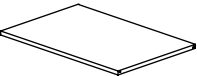

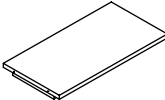
Assembly Instructions

LS-24

24" Adjustable Lan Station

Part	Drawing	Description	Qty	Part	Drawing	Description	Qty
P-1		Leg Frame	2 EA	Hardware List			
P-2		Right Slide Assembly	2 EA	A		Flat Head Screw M6X15	24 EA
P-3		Left Slide Assembly	2 EA	A1		Flat Head Screw M6X40	4 EA
P-4		Brace	1 EA	B		Phillips Head Wood Screw	8 EA
P-5		Shelf	3 EA	C		Interior Threaded Post	16 EA
P-6		Keyboard Platform	2 EA	D		2" Locking Caster (for Front)	2 EA
P-7		Shelf Brackets	4 EA	E		2" Caster (for Back)	2 EA
				F		Slide	4 EA
				G		Allen Wrench	1 EA
				H		Caster Wrench	1 EA

Tools Required: Philips Head Screw Driver

READ THROUGH INSTRUCTIONS FROM BEGINNING TO END BEFORE STARTING TO ASSEMBLE UNIT.

Missing Parts or UPS Damaged Parts

For Your Convenience you can
EMAIL us at

susanthompson@baltinc.com

24HOURS 7 DAYS A WEEK

***Should you require assistance during assembly,
please call our Customer Service Department***

Monday - Friday 8 a.m. - 5 p.m.

Central Standard Time 1-800-749-2258

Do not use unless all screws are tight. At least every six months,
check all screws to be sure they are tight.
If parts are missing, broken, damaged, or worn, stop use of the product
until repairs are made by your dealer using factory authorized parts.

LS-24 Assembly Diagram



Illustration # 1

To Assemble:

1. Identify and Separate all the Parts and Hardware.
2. Attach 2 Right Slide assemblies (P-2) to 1 Leg Frame (P-1) using 4 Flat Head screws (A) and 4 Interior Threaded Posts (C) as shown in illustration # 1. Attach 2 Left Slide assemblies (P-3) to the second Leg Frame (P-1) using 4 Flat Head screws (A) and 4 Interior Threaded Posts (C).

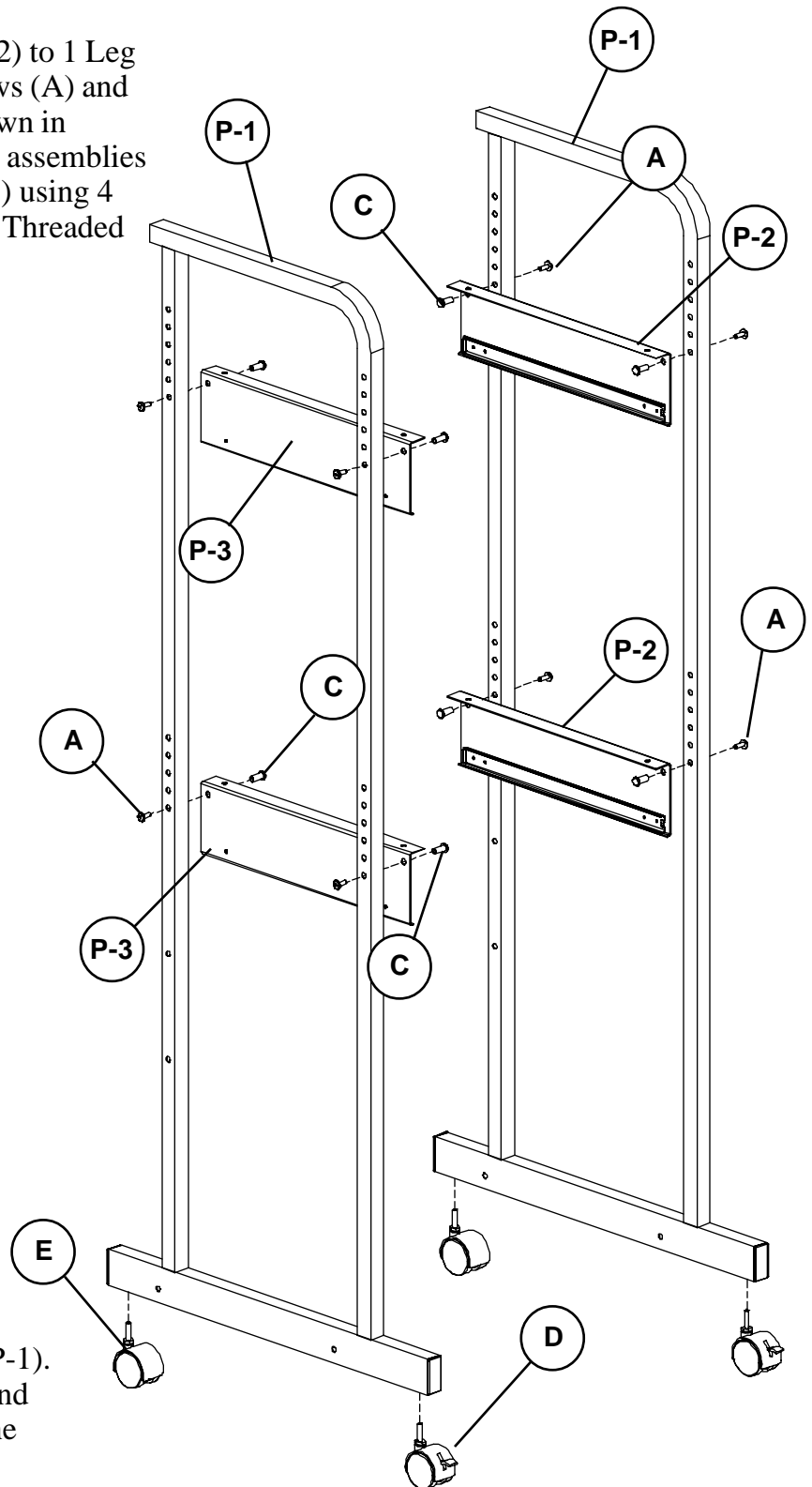

3. Attach Casters to the Leg Frames (P-1). 2 Locking casters (D) in the front and 2 Casters (E) in the back. Tighten the Casters using Caster Wrench (H).

LS-24

Assembly Diagram



4. Attach 1 Shelf (P-5) to 2 Leg Frames (P-1) using 4 Flat Head screws (A) as shown in illustration # 2.
5. Attach 1 Brace (P-4) to the 2 Leg Frames (P-1) using 4 Flat Head screws (A1), and 4 Interior Threaded Posts (C).

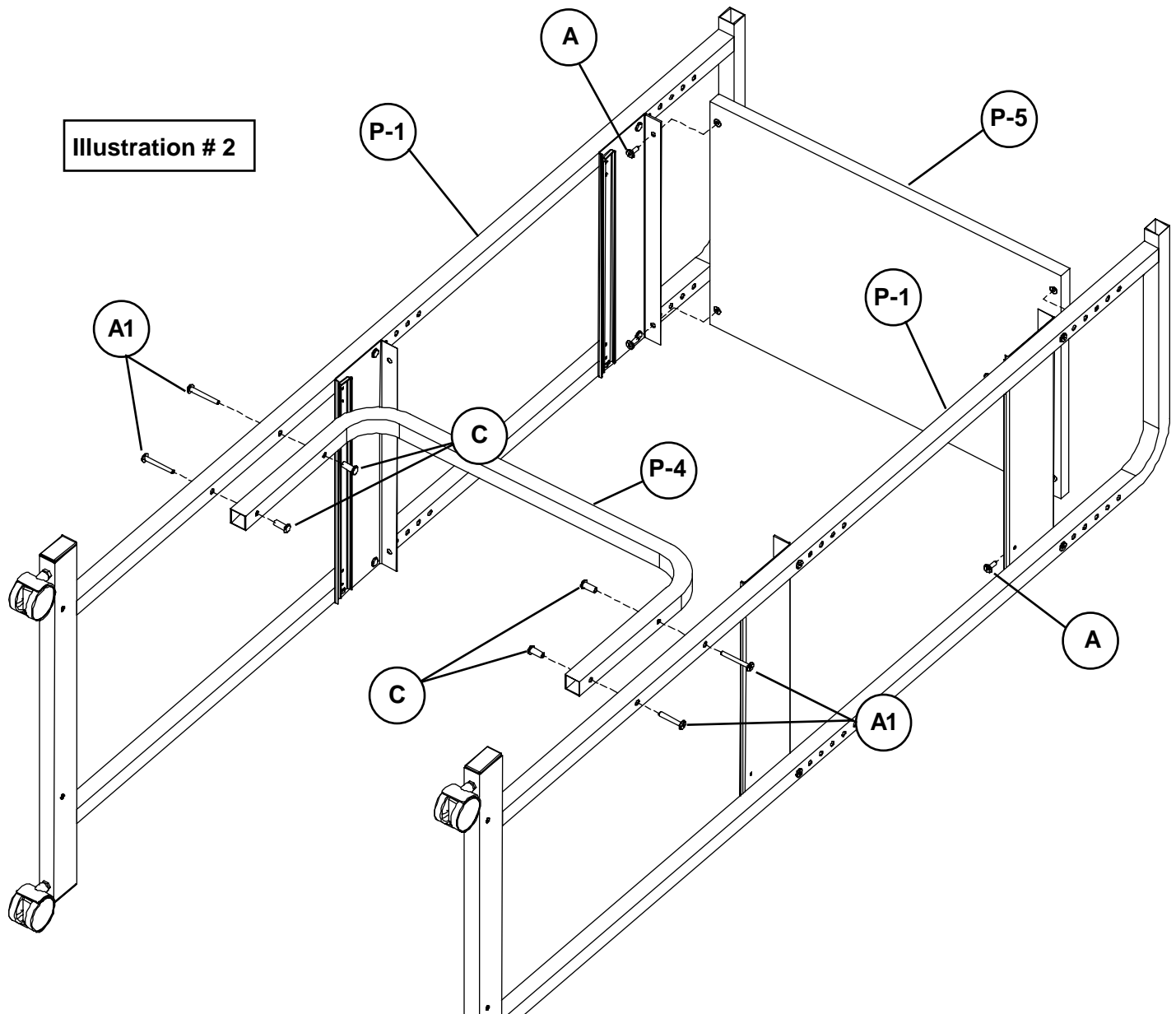

6. Attach 4 Shelf Brackets (P-7) to 1 of the remaining 2 Shelves (P-5) using 4 Flat Head screws (A) as shown in illustration # 3.

7. Attach the 1 Shelf (P-5) with Brackets to the bottom of 2 Leg Frames (P-1) using 4 Flat Head screws (A) and 4 Interior Threaded Posts (C) as shown in illustration # 4.

8. Attach the remaining 1 Shelf (P-5) in the middle of 2 Leg Frames (P-1) at the desired height using 4 Flat Head screws (A) as shown in illustration # 4.

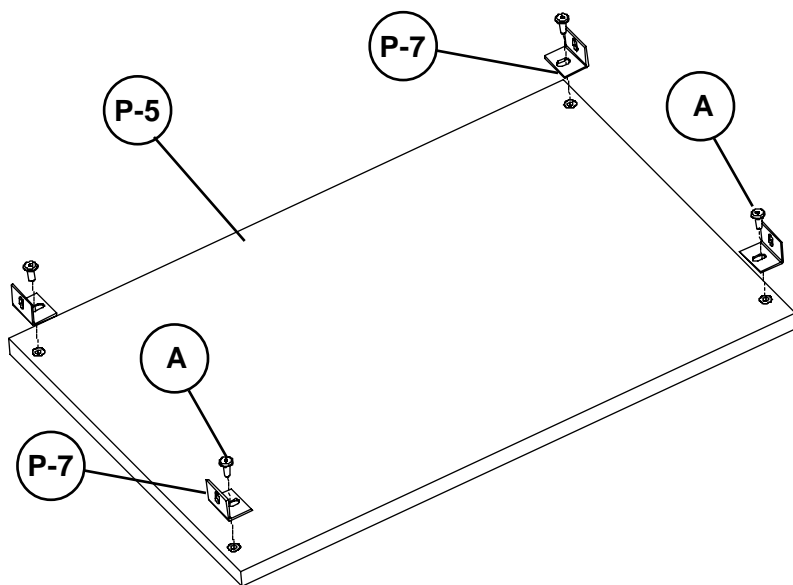

Illustration # 3

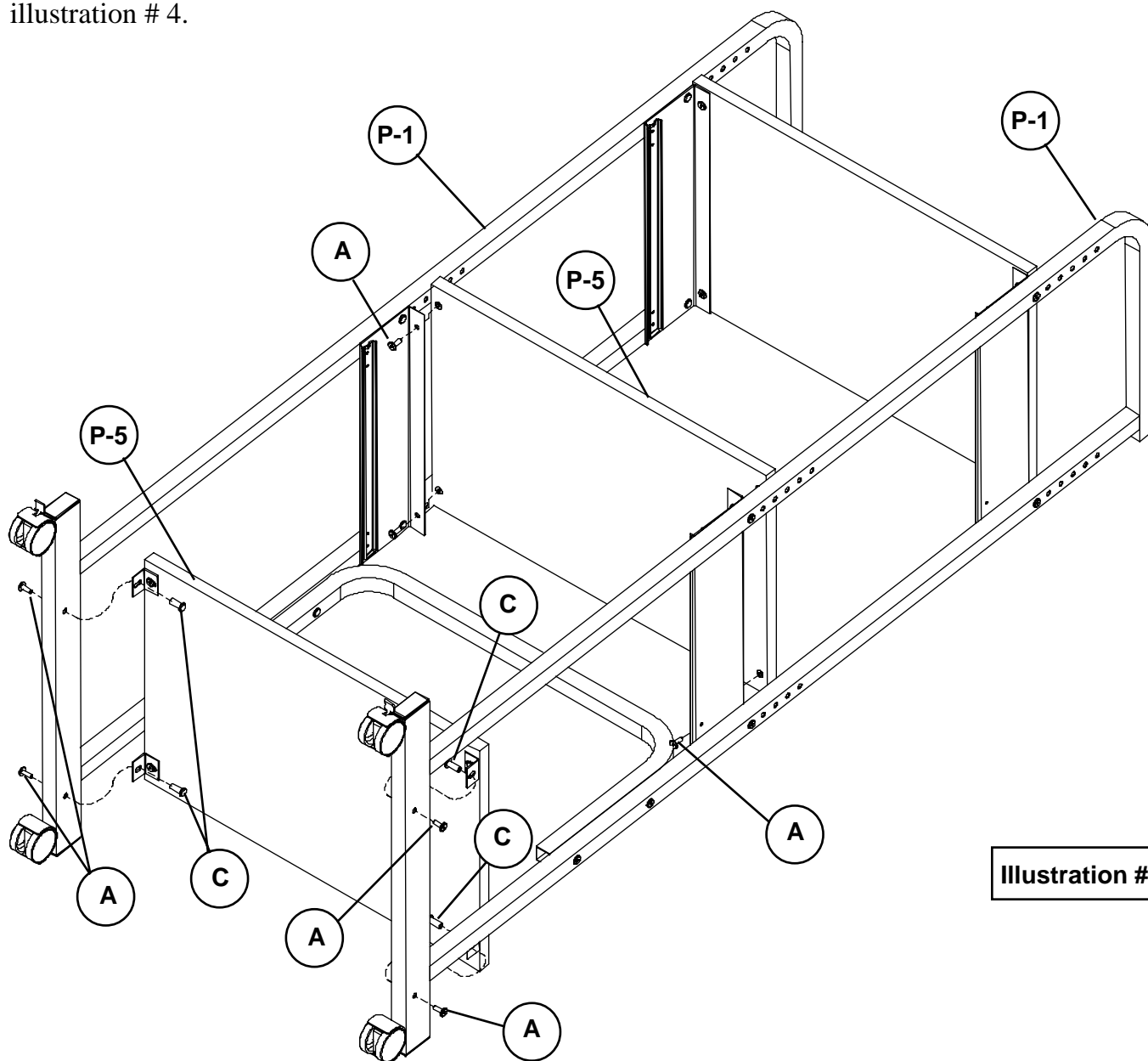

Illustration # 4

9. Attach 4 slides (F) to 2 Keyboard Platforms (P-6) using 8 Philips Head Wood Screws (B) as shown in illustration # 5.
10. Place the unit in upright position. Insert 2 Keyboard assemblies into the Right and Left Slide assemblies (P-2 & P-3) as shown in illustration # 5.
11. Tighten all screws securely using Allen Wrench (G).

