

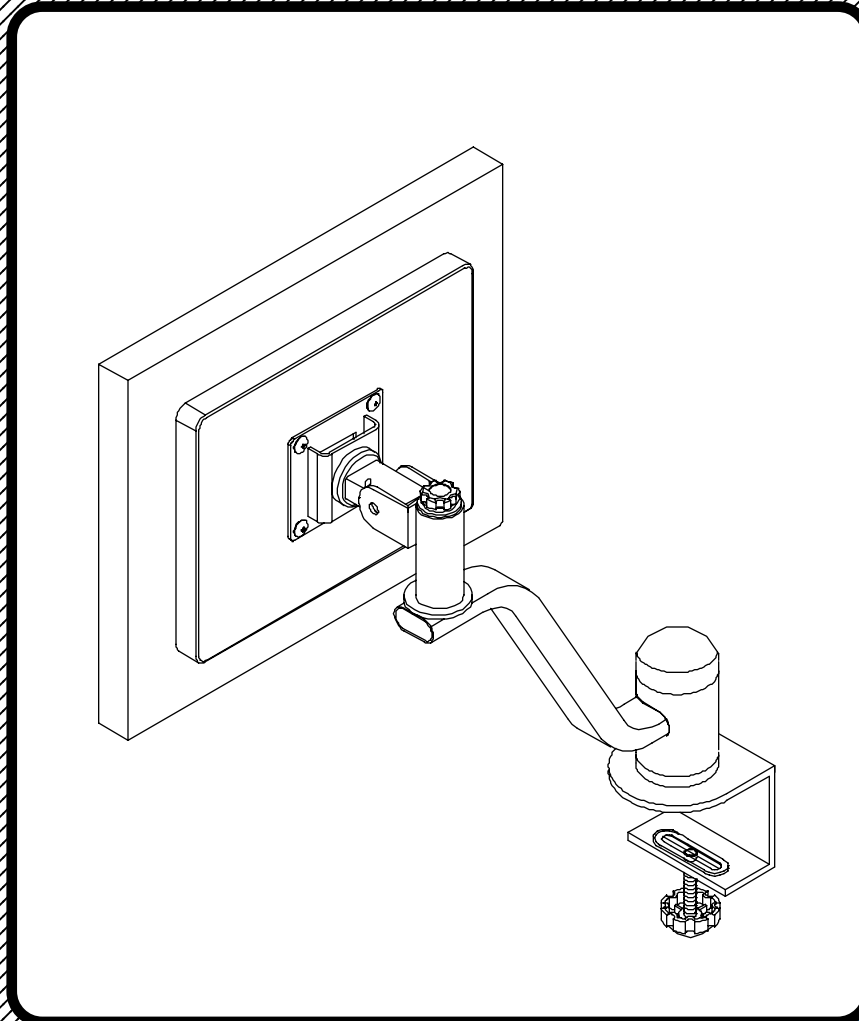

BLT-66453









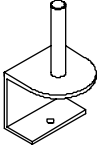
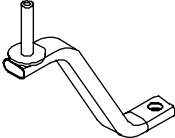

Fixed Height LCD monitor Arm

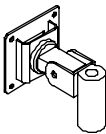

Assembly Instructions

BLT-66453

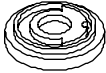
Fixed Height LCD Monitor Arm

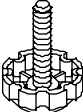
Part	Drawing	Description	Qty	Part	Drawing	Description	Qty
P1		Monitor Arm Base	1 EA	Hardware List			
P2		Monitor Arm	1 EA	A		Small Knob	1 EA
P3		LCD Swivel Tube	1 EA	B		Plastic Washer	1 EA
P4		LCD Mounting Bracket	1 EA	C		Steel Washer	1 EA
P3		LCD Mounting Bracket	1 EA	D		Steel Plate	1 EA
<p>This unit fits VESA compatible Flat Panel Displays and comes with a 75 mm VESA plate.</p>				E		Foam Pad w/Adhesive	1 EA
				F		Plastic Sleeve	2 EA
				G		Plastic Cap	1 EA
				H		Large Knob	1 EA

READ THROUGH INSTRUCTIONS FROM BEGINNING TO END BEFORE STARTING TO ASSEMBLE UNIT.

1. Identify and Separate all the Parts and Hardware.
2. Peel and attach Adhesive Foam Pad (E) to the Monitor Arm Base (P-1) as shown in illustration #1.
3. Insert Large Knob (H) into the Monitor Arm Base (P-1) as shown in illustration #1. Thread Large Knob (H) through the Monitor Arm Base (P-1) until ¼" of threads are visible.
4. Place Steel Plate (D) over the end of Large Knob (H) as shown in illustration #1.

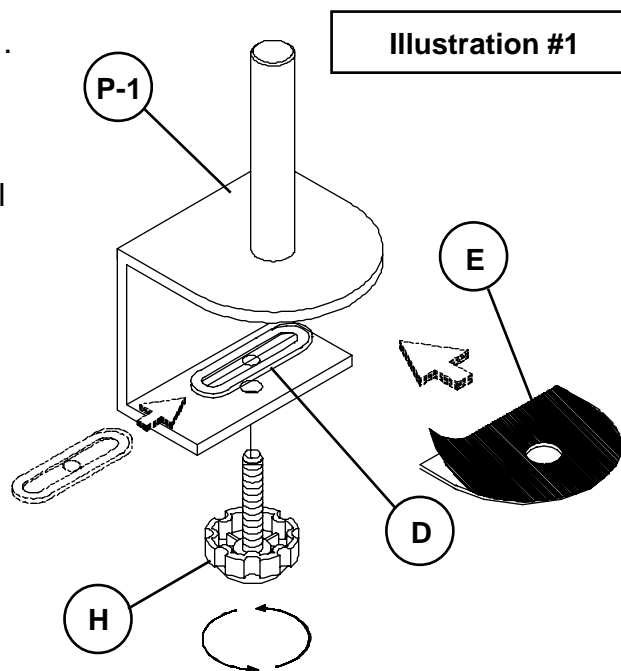

Missing Parts or UPS Damaged Parts
 For Your Convenience you can
 EMAIL us at
furniture@baltinc.com
 24HOURS 7 DAYS A WEEK

BLT-66453 Assembly Diagram



5. Slide 1 Plastic Sleeve (F) over the Monitor Arm Base (P-1) as shown in illustration #2.
6. Insert Monitor Arm (P-2) into hole in the side of LCD Swivel Tube (P-3) and slide down over the Monitor Arm Base (P-1) as shown in illustration #2.
7. Slide Second Plastic Sleeve (F) over the Monitor Arm Base (P-1) as shown in illustration #2.
8. Slide 1 Plastic Cap (G) over the Monitor Arm Base (P-1) as shown in illustration #2.

Illustration #2

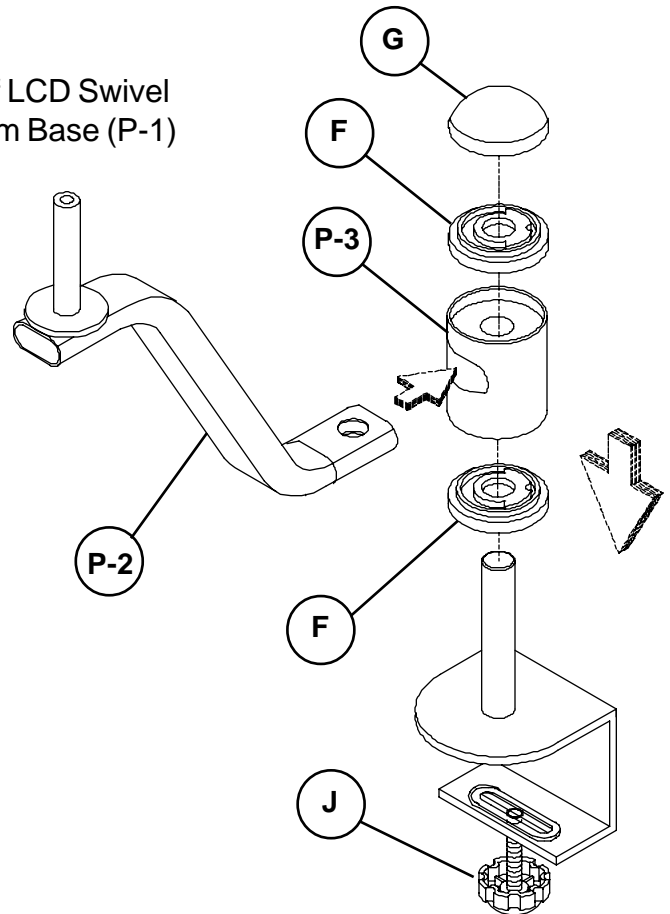
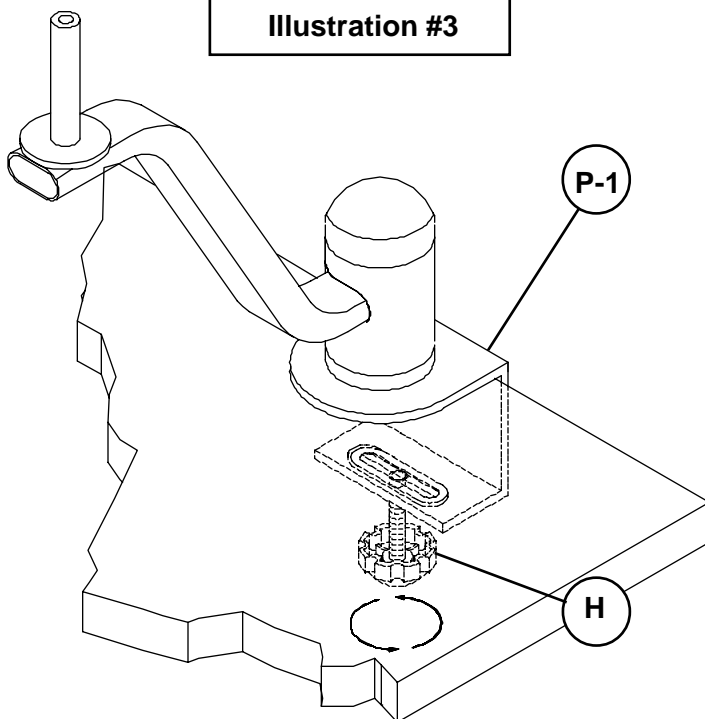

Illustration #3



Be sure that the desktop is at least 3/4" thick.

9. Slide the Monitor Arm Base (P-1) onto the desktop until the side of the desktop touches the clamp as shown in illustration #3.
10. Secure Monitor Arm Assembly (P-1) to the desktop by tightening Knob (H)

**Should you require assistance during assembly, please call our Customer Service Department
Monday - Friday 8 a.m. - 5 p.m.
Central Standard Time
1-800-749-2258**

Do not use unless all screws are tight. At least every six months, check all screws to be sure they are tight. If parts are missing, broken, damaged, or worn, stop use of the product until repairs are made by your dealer using factory authorized parts.

Illustration #4

11. Remove LCD Flat Panel Display from current Base, and attach Flat Panel Display to the LCD Mounting Bracket (P-4) using the 4 each Small Screws from original LCD Support as shown in illustration #4.

Small Screw
(Not Included)

P-4

LCD Flat Panel
Display

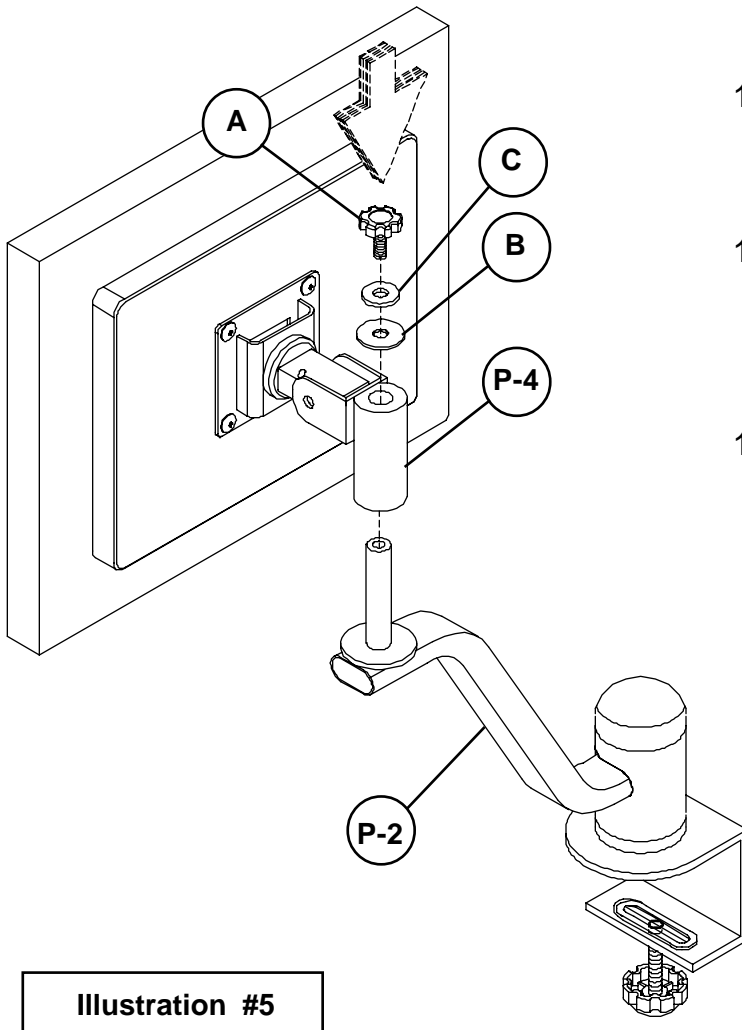
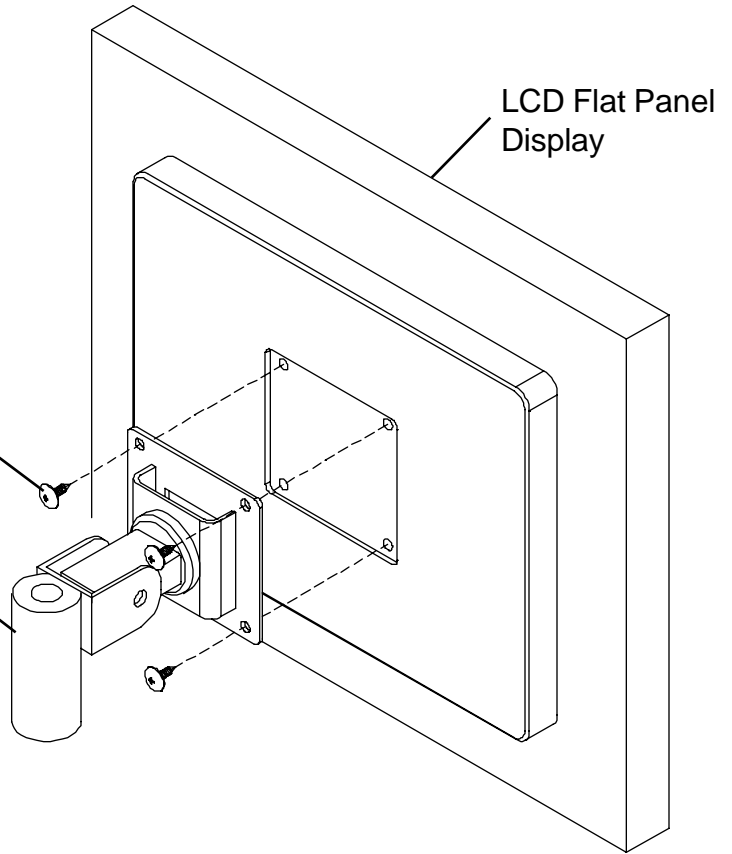

Illustration #5

12. Slide LCD Mounting Bracket (P-4) over the Monitor Arm (P-2) as shown in illustration # 5.

13. Insert Small Knob (A) through Steel Washer (C) and Plastic Washer (B) and into hole in LCD Mounting Bracket (P-4) as shown in illustration # 5.

14. Tighten Small Knob (A).