

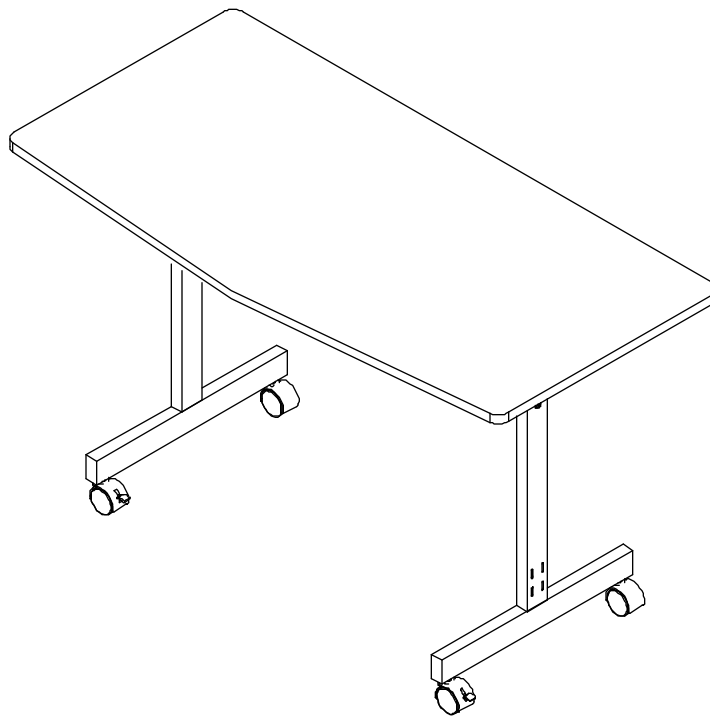

#89768

# AP Table











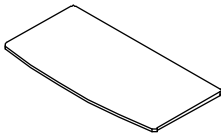
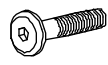





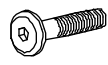

All Purpose Table

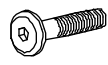

# Assembly Instructions

# AP Table

## All Purpose Table

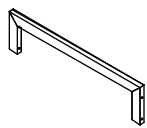
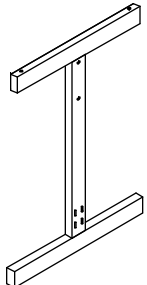
Part	Drawing	Description	Qty	Part	Drawing	Description	Qty																												
P1		Top Platform	1 EA	<div style="border: 2px solid black; border-radius: 15px; padding: 10px;"> <h3 style="text-align: center;">Hardware List</h3> <table style="width: 100%; border-collapse: collapse;"> <tr> <td style="width: 5%;">A</td> <td style="width: 10%;"></td> <td style="width: 65%;">2 3/8" Socket Screw</td> <td style="width: 20%;">8 EA</td> </tr> <tr> <td>B</td> <td></td> <td>Interior Threaded Post</td> <td>4 EA</td> </tr> <tr> <td>C</td> <td></td> <td>2" Locking Caster</td> <td>2 EA</td> </tr> <tr> <td>D</td> <td></td> <td>2" Caster</td> <td>2 EA</td> </tr> <tr> <td>E</td> <td></td> <td>Leveling Glides</td> <td>4 EA</td> </tr> <tr> <td>F</td> <td></td> <td>Allen Wrench</td> <td>2 EA</td> </tr> <tr> <td>G</td> <td></td> <td>Caster Wrench</td> <td>1 EA</td> </tr> </table> <p style="text-align: center; margin-top: 10px;"><i>We recommend that you assemble this unit on a table.</i></p> </div>				A		2 3/8" Socket Screw	8 EA	B		Interior Threaded Post	4 EA	C		2" Locking Caster	2 EA	D		2" Caster	2 EA	E		Leveling Glides	4 EA	F		Allen Wrench	2 EA	G		Caster Wrench	1 EA
A		2 3/8" Socket Screw	8 EA																																
B		Interior Threaded Post	4 EA																																
C		2" Locking Caster	2 EA																																
D		2" Caster	2 EA																																
E		Leveling Glides	4 EA																																
F		Allen Wrench	2 EA																																
G		Caster Wrench	1 EA																																
P2		Metal Stability Brace	1 EA																																
P3		Leg	2 EA																																

### Missing Parts or UPS Damaged Parts

For Your Convenience you can  
EMAIL us at  
**[furniture@baltinc.com](mailto:furniture@baltinc.com)**  
24HOURS 7 DAYS A WEEK

### *Should you require assistance during assembly,*

*please call our Customer Service Department  
Monday - Friday 8 a.m. - 5 p.m.  
Central Standard Time 1-800-749-2258*

Do not use unless all screws are tight. At least every six months, check all screws to be sure they are tight. If parts are missing, broken, damaged, or worn, stop use of the product until repairs are made by your dealer using factory authorized parts.

# AP Table Assembly Diagram



**READ THROUGH INSTRUCTIONS FROM BEGINNING TO END BEFORE STARTING TO ASSEMBLE UNIT.**

- 1.) Identify and Separate all the Parts and Hardware.
- 2.) Attach Stability Brace(P2) to the 2 each Legs (P3) using 4 Screws (A) and 4 Interior Threaded Posts (B) as shown in illustration #1. **(Finger tighten only)**

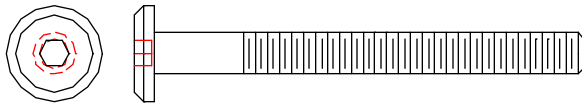

(A) Screw M6 X 2-3/8"  
For Scale only

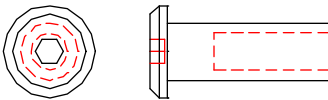

(B) Interior Threaded Post  
M6 X 7/8"  
For Scale only

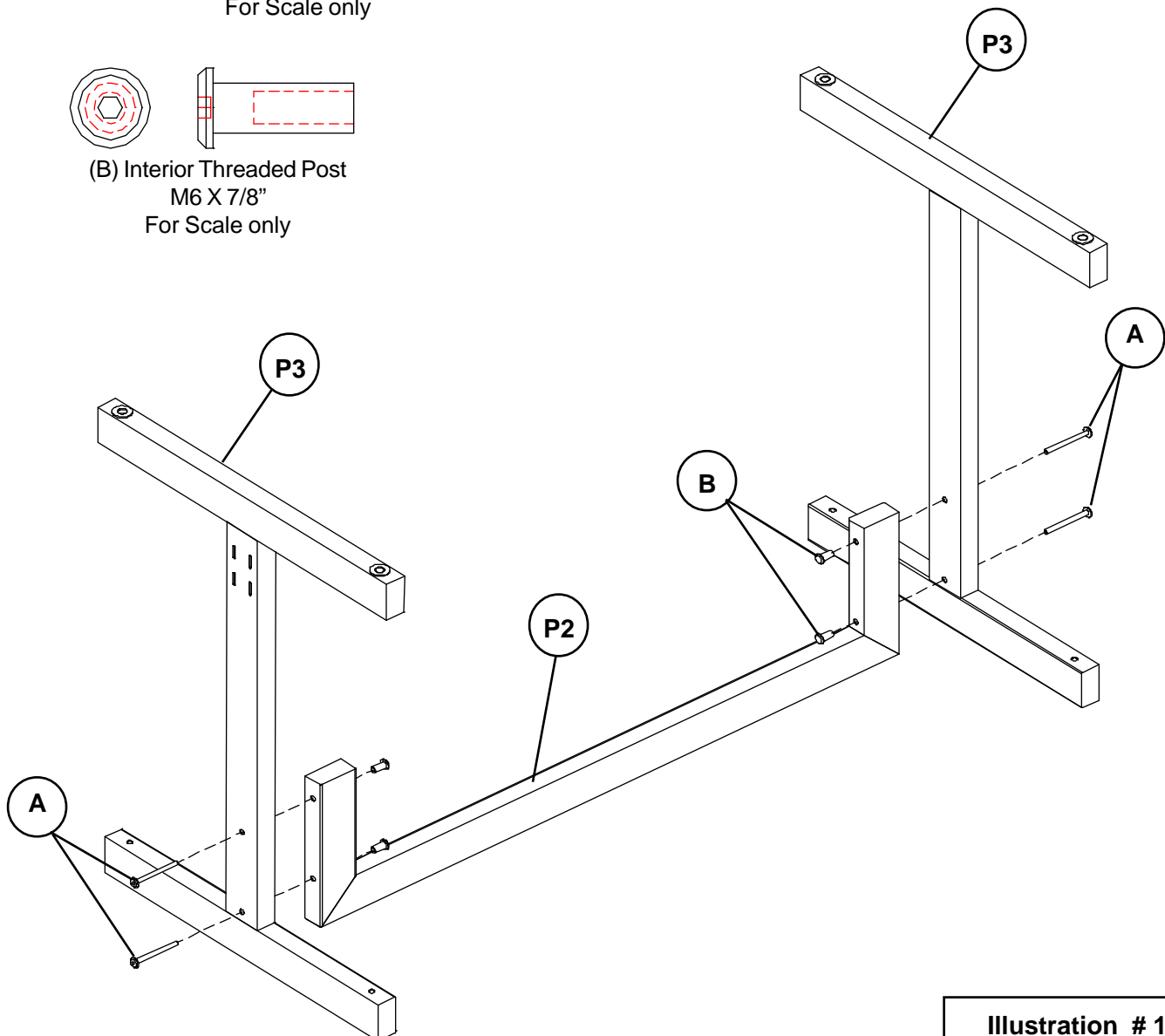
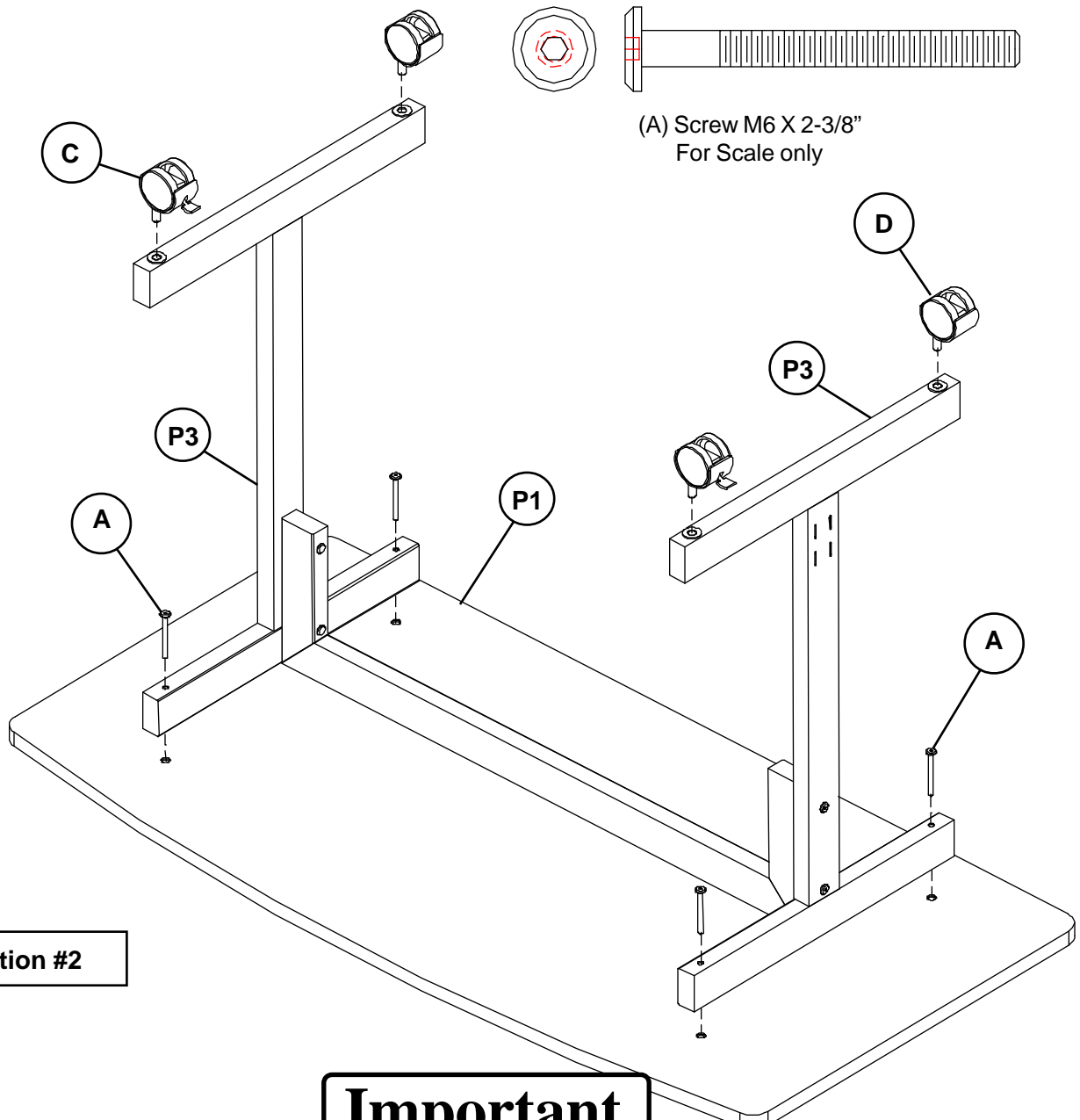

Illustration # 1

- 3.) Attach 2 each Legs (P3) to the Top Platform (P-1) using 4 each (A) screws as shown in illustration # 2. **Tighten all the screws at this time using Allen Wrench (F).**
- 4.) Attach 2 each (C) Locking Casters to the front of the 2 each Legs (P-3) and 2 each (D) Casters to the back of the Legs (P-3) as shown in illustration #2 . Tighten Casters using Caster Wrench (G). (Use 4 each (E) Leveling Glides in place of Casters for stationary use.)



**Illustration #2**

## Important

The Balt product you have purchased is guaranteed against material and workmanship defects. This guarantee extends 1 year from date of purchase. Should this product fail to function satisfactorily under normal use due to defect or imperfection, the defective part or product will be replaced. Damage caused by common carriers during shipment is not included in this guarantee.

**This guarantee sets forth all applicable guarantees and remedies. No other warranty, expressed or implied shall apply. Failure to follow instructions found in Important Information Section of Owner Sheet shall void the guarantee. Consequential or incidental damages and or costs are not refundable.**