

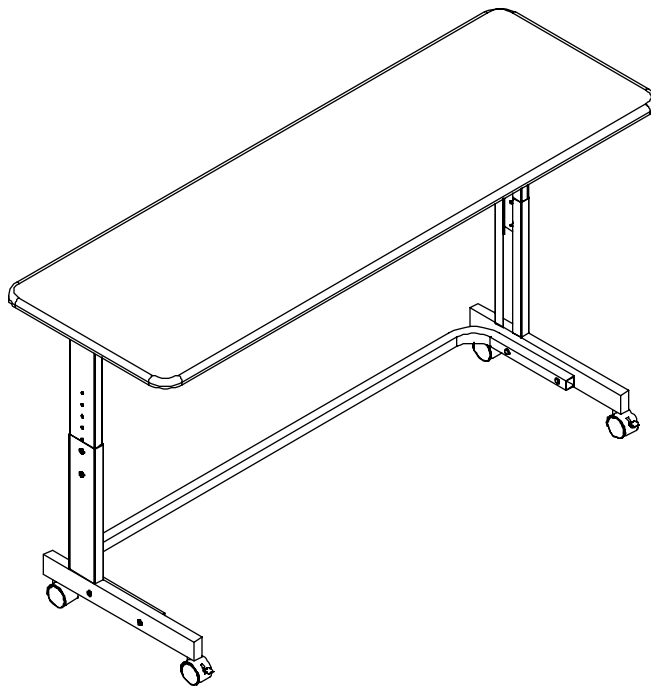

#89793 ST-2060

Adjustable Height Seminar Table



Assembly Instructions

#89793 ST-2060

Seminar Table

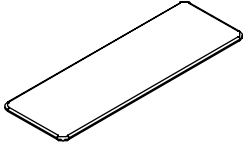
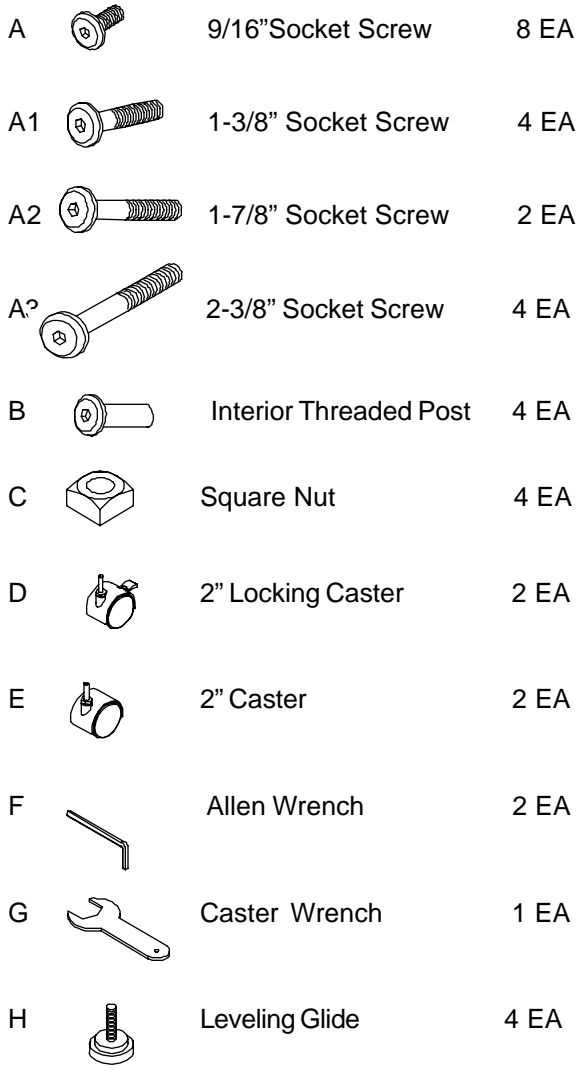
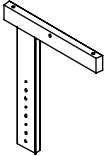
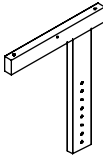
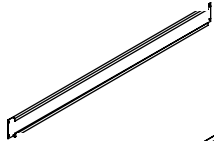
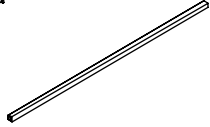
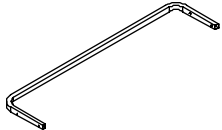
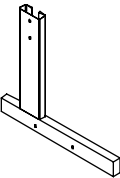
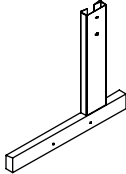
Part	Drawing	Description	Qty	Part	Drawing	Description	Qty
P1		Top Platform	1 EA	Hardware List 			
P2		Left Upper Insert	1 EA				
P3		Right Upper Insert	1 EA				
P4		Stability Panel	1 EA				
P5		Upper Crossbrace	1 EA				
P6		Lower Crossbrace	1 EA				
P7		Left Leg Receiver	1 EA				
P8		Right Leg Receiver	1 EA				
				<i>We recommend that you assemble this unit on a table.</i>			

Missing Parts or UPS Damaged Parts

For Your Convenience you can
EMAIL us at
furniture@baltinc.com
24HOURS 7 DAYS A WEEK

***Should you require assistance during assembly,
please call our Customer Service Department
Monday - Friday 8 a.m. - 5 p.m.
Central Standard Time 1-800-749-2258***

Do not use unless all screws are tight. At least every six months, check all screws to be sure they are tight. If parts are missing, broken, damaged, or worn, stop use of the product until repairs are made by your dealer using factory authorized parts.

#89793 ST-2060 Assembly Diagram

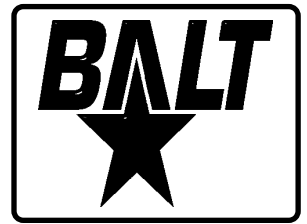

READ THROUGH INSTRUCTIONS FROM BEGINNING TO END BEFORE STARTING TO ASSEMBLE UNIT.

- 1.) Identify and Separate all the Parts and Hardware.
- 2.) Place the Top Platform (P1) with the insert nuts facing up. Attach 1 each Left Upper Insert (P2) and 1 each Right Upper Insert (P3) using 4 each screws (A3) as shown in illustration #1.

(Finger tighten only)

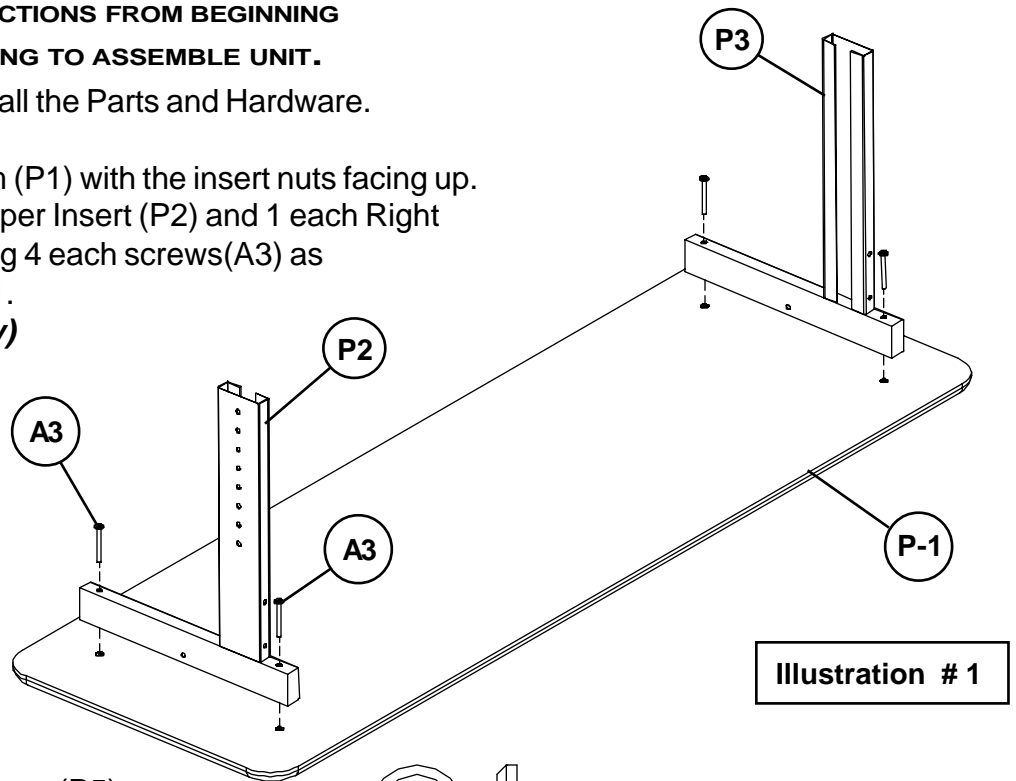

- 3.) Attach Upper Crossbrace (P5) between the Left Upper Insert (P2) and the Right Upper Insert (P3) using 2 Screws (A2) as shown in illustration #2.

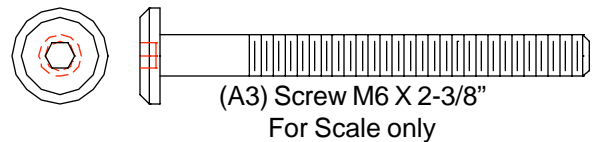

- 4.) Attach Stability Panel (P4) to the Upper Inserts (P2 & P3) using 4 Screws (A) as shown in illustration #2.

(Finger tighten only)

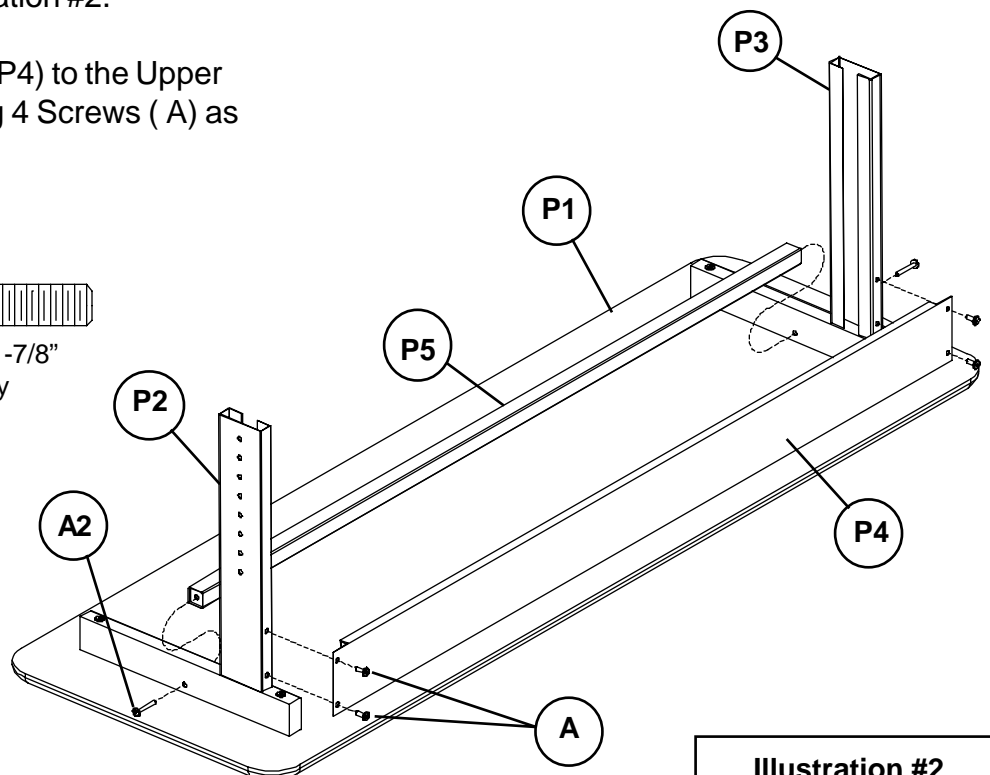
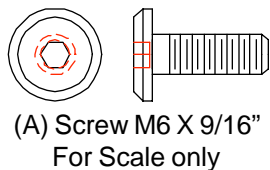
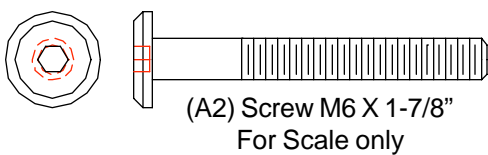

Slide 1 Left Leg Receiver (P7) and 1 Right Leg Receiver (P8) over 1 Left Upper Insert (P2) and 1 each Right Upper Insert (P3) as shown in illustration #3. Secure at desired height using 4 each (A) Screws and 4 each (C) Square nuts (flat side of the nut should be next to the metal).

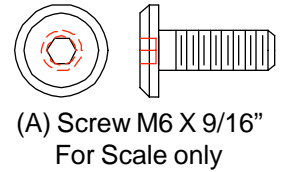

Attach Lower Crossbrace (P6) between the 2 each Lower Leg Receivers (P-7/P-8) using 4 each Socket Screws (A1) and 4 each Interior Threaded Posts (B) as shown in illustration #3.

(Tighten all the screws at this time using Allen Wrench (F)).

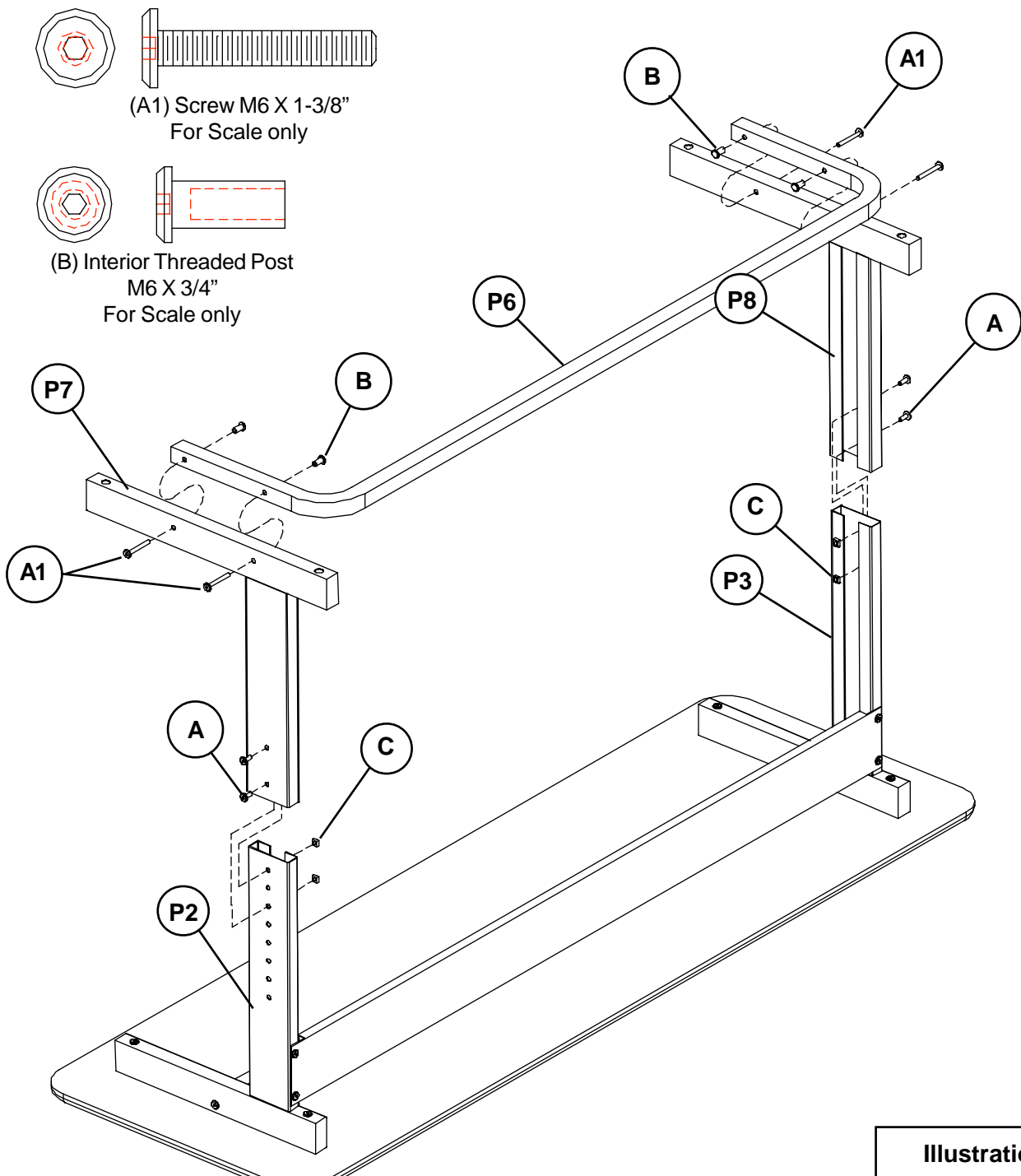

4.) Attach 2 each Locking Casters (D) to the front of the 2 each Lower Leg Receivers (P7&P8) and 2 each Casters (E) to the back of the 2 each Lower Leg Receivers (P7&P8) as shown in illustration #4.



Tighten Casters using Caster Wrench (G).
Use 4 each Leveling Glides (H) in place of Casters for stationary use.

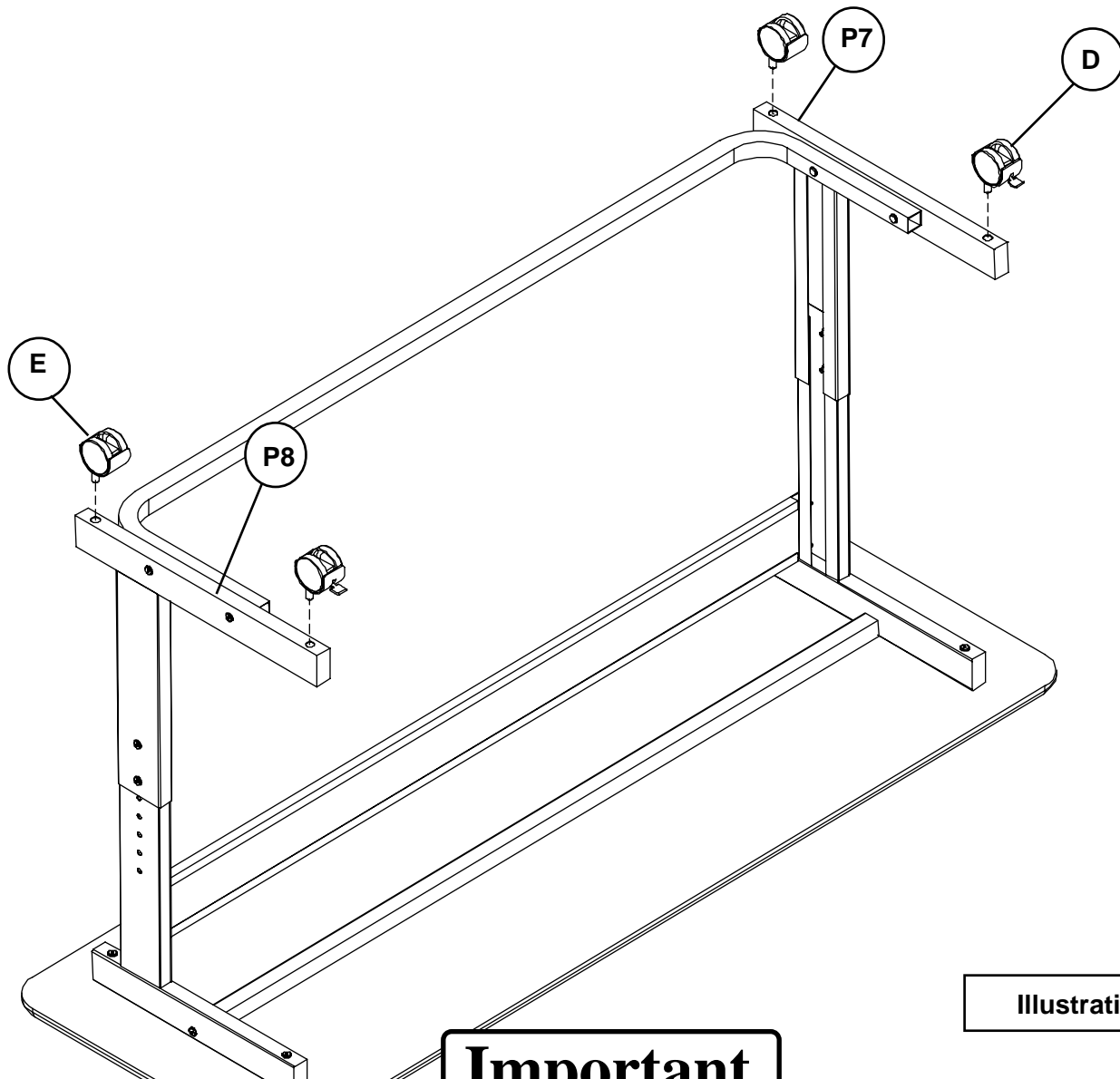

Illustration #4

Important

The Balt product you have purchased is guaranteed against material and workmanship defects. This guarantee extends 1 year from date of purchase. Should this product fail to function satisfactorily under normal use due to defect or imperfection, the defective part or product will be replaced. Damage caused by common carriers during shipment is not included in this guarantee.

This guarantee sets forth all applicable guarantees and remedies. No other warranty, expressed or implied shall apply. Failure to follow instructions found in Important Information Section of Owner Sheet shall void the guarantee. Consequential or incidental damages and or costs are not refundable.